



Roller Guide 5 D6
Notes on Use and Installation

Content

General safety information.....	2
Correct use.....	3
Application options.....	4
Assembly guides.....	4
Lubrication.....	6

General safety information

The data and the information contained in the Notes on Use and Installation are intended exclusively for product description and assembly. The information does not release the user from conducting their own assessments and checks. It should be noted that our products are subject to natural wear and tear as well as an aging process.

These Notes on Installation and Use include important information for the safe and appropriate use of the product. In the case of a sale, rent or other transmission of the product, the latter must be accompanied by the Notes on Use and Installation. During the assembly, operation and maintenance of the driven linear unit, it must be ensured that all moving parts are secured against accidental switch-on or moving. Rotating and moving parts can lead to serious injury! Please make sure to read and observe the following safety precautions.

- Any work with or close to the driven linear unit must be performed under the motto “safety first”.
- Switch the drive unit off before you begin a task close to the driven linear unit.
- Secure the drive unit against accidental switch-on, e.g. by installing signs near the switch or remove the fuse from the power supply.
- Do not reach into the working area of the moving parts of the driven linear unit while it is operating.
- Secure the moving parts of the driven linear unit against accidental contact by installing protective devices and enclosures.
- Please take note of the applicable regulations for accident prevention and environmental protection in the country of use and the workplace.
- Use item products only in technically perfect condition.
- Non-use of original spare parts leads to the expiry of the warranty!
- Check if the product has obvious defects.
- Use the product exclusively within the range of performance described in the technical data.
- Make sure all the safety devices belonging to the product are available, suitably installed and fully functional.

You are not allowed to change the position of, avoid or disable safety devices.

The driven linear unit described here corresponds to the state-of-the-art and respects the general principles of safety at the date of printing of the present Notes on Use and Installation. Nonetheless, the hazard for personal injury and damage to property remains when the fundamental safety instructions and warning notices mentioned in the present Notes on Use and Installation are not observed. We accept no liability for any damage that may arise from them. In the interest of further development, we reserve ourselves the right to technical changes. Keep the present Notes on Use and Installation readily accessible to all users. Please take notice of the superordinate instructions for use of the complete machinery or equipment. The general hazard warning refers to the whole life cycle of the partly completed machinery.

1. Transport

Please note the transport instructions on the packaging. Make sure to leave the product in the original packaging and protect it from humidity and damage until assembly. Please note that moving parts are fixed and can cause no damage during transport.

2. Assembly

Always switch the relevant system component off-circuit before you assemble the product or plug/unplug it. Secure the system against re-starting. Lay the cables and conducts so that they cannot be damaged and nobody can trip over them. Avoid places with risk of slipping, tripping or falling.

3. Putting into service

Let the product acclimatise for some hours before putting it into service. Make sure the partly completed machinery is tightly and safely integrated to the complete machinery. Only put fully installed products into service.

4. During operation

Allow the access to the direct operational area of the system only to people authorised by the operator. This also applies for downtimes of the system. Moving parts must not be accidentally actuated. In case of emergency, error or other irregularities, switch off the system and secure it against restarting. Make sure people cannot be shut in the system's danger zone.

5. Cleaning

Close all openings with appropriate protective devices so that no detergent can enter the system. Use no aggressive detergents. Do not use a high-pressure cleaner for the cleaning.

6. Putting into service and maintenance

Perform the required maintenance work in the time intervals described in the operating instructions. Make sure no connection line, connection or component is released until the system is under pressure and tension. Secure the system against restarting.

7. Disposal

Dispose of the product according to the national and international provisions of your country.

Correct use

The driven linear unit is a product in accordance with the Machinery Directive 2006/42/EC (partly completed machinery). The driven linear unit can only be used in accordance with the technical data and safety regulations of the present documentation. The internal rules and guidelines of the country of use must be respected. Unauthorised structural changes to the driven linear unit are not permitted. We accept no liability for any damage that may arise from them.

You are authorised to assemble, operate and maintain the drive linear unit only if:

- The driven linear unit has been integrated to the complete machinery according to the intended applications and safety requirements.
- You have read the Notes on Use and Installation carefully and understood them.
- You are qualified.
- You have the authorisation of your company.
- You exclusively use the original accessories of the manufacturer.

In case of unsafe and inappropriate operation of the driven linear unit, there is a danger of serious injury from crush and shear points.

Inappropriate use

The inappropriate use refers to applications differing from the use authorised by the Notes on Use and Installation and the appropriate use. We accept no liability for any damage that may arise.

Application options

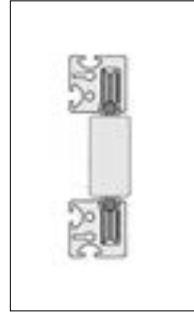
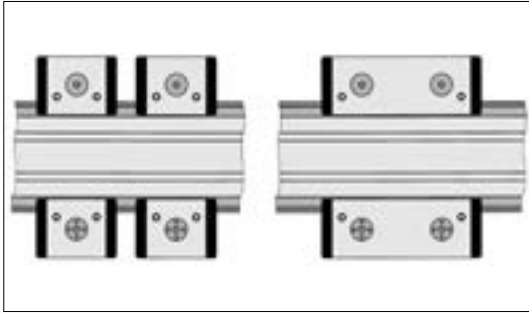

To construct a linear guide, two centric (fixed) and two eccentric (adjustable) bearing units are normally required. Each pair of single bearing units can be replaced by one double bearing unit. More bearing units can be used if required.

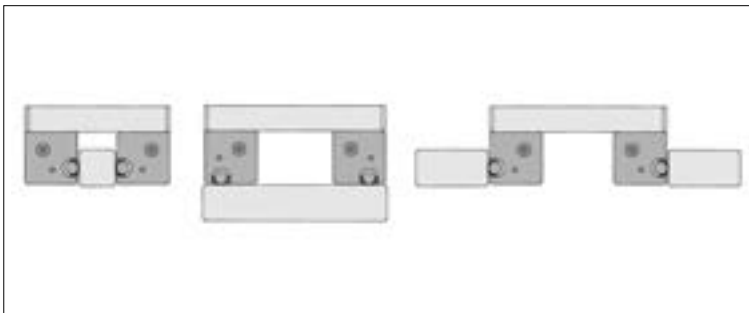

The roller profiles provide a variety of fastening options using the grooves of Line 8 Profiles, this greatly simplifying installation and alignment on profiles or carriage plates.

Assembly guides

Shaft-Clamp Profile and Shaft:

The supporting profile, Shaft-Clamp Profile and Shaft can be assembled in a variety of ways.

To facilitate installation, a film of oil or grease should be applied to the outer surfaces of the Shaft-Clamp Profile in contact with the support profile prior to insertion into the groove. The same applies to the contact points between the Shaft and Shaft-Clamp Profile and to the guiding shaft.

In the case of short support profiles which are not yet built into the structure, the assembly is best done in the following sequence:

- A Shaft-Clamp Profile is pressed into the relevant groove in the Support Profile
- The Shaft is pressed in using a vice (use protective jaw)
- Second side in same sequence

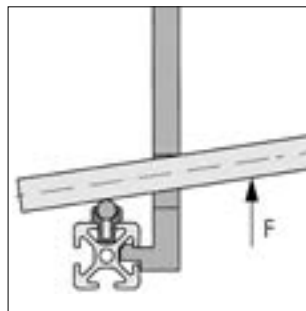
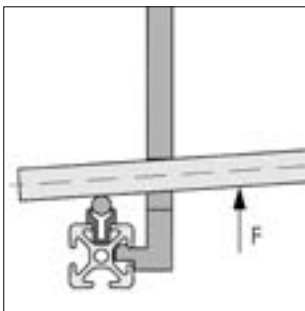

With longer sections where the support profiles have already been installed or are held in a vice, for example, it is possible after inserting the Shaft-Clamp Profile to press the Shaft into the latter progressively, starting at one end by using the Mounting Aid (Order No. 0.0.265.38) and an appropriate round steel bar as a lever.

Guide carriage/bearing units:

Bearing units can be fitted to all MB System profile elements as well as to all other elements. The standard grooves can be used to secure the bearing units using two different methods:

- The heads of the Button-Head Screws and washers are located within one of the bearing unit grooves. In order to access the screws, holes for the hexagon key are required at the relevant positions. Suitable holes are already provided in the bearing units for the most popular fastening position. In other fastening positions, holes will need to be drilled.
- The T-Slot Nuts are located within one of the bearing unit grooves and the fastening screws are inserted through the carriage plate.

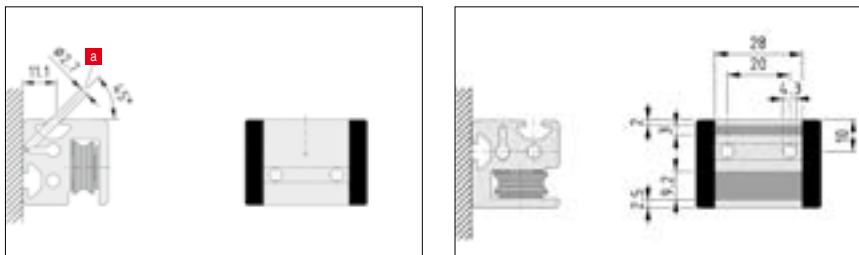
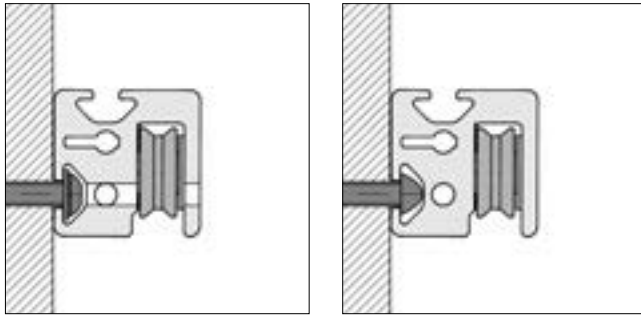

a dowel DIN 6325-3x12

It is strongly recommended that all bearings are secured to the carriage plate by means of pinning. This can be done by using the predrilled dowel holes or by drilling and pinning **a** in any of the areas marked dark grey on the following illustrations.

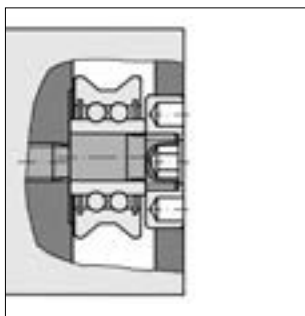

The eccentric bearing units must be set prior to the guide carriage being used. The Allen key drives in the rollers' eccentric bolt:

- Drive in the bolt as far as it will go
- Turn back ½ revolution
- Turn back further until the bearing is as far into the housing as possible.

Where bearing units are prepared and fitted in this way, the full eccentricity is available during final setting. The bearing units should be set so that play is eliminated but without any preload, so as to avoid excessive strain.

After the setting has been made, the eccentric bolt must be firmly fixed in position by the round nut using a pin spanner (M). The bolt must be held in the set position using a hexagon key during this operation.

M = 3 Nm

Lubrication

End Cap and Lubricating Systems are essential in order to protect and lubricate the Bearing Units. It is inadvisable to fit the End Caps until the carriage has been assembled on the guiding shafts. It is also important to ensure that the spring-loaded wipers are pushed back if the carriage is removed and refitted, thereby preventing buckling of the wipers.

The inside pockets of the End Cap and Lubricating Systems on the end face contain wipers which are also used to hold the lubricant. They are pressed against the guiding shaft by means of a spring. These wipers are supplied oil-filled and can be topped up by means of the hole in the cap.

Suitable lubricants include all good machine lubrication oils, bed track oils and gear oils both with and without additives such as MoS₂.

The wipers may need to be changed should they become too damaged or dirty.

item

item Industrietechnik GmbH
Friedenstrasse 107-109
42699 Solingen
Germany
Phone +49 212 6580 0
info@item24.com
item24.com