



The item Conveyor Belt System  
Assembly guide

## Contents

Symbols, safety .....	3
General safety information .....	3
Correct use .....	4
Improper use.....	5
Special safety instructions.....	5
Personnel qualifications .....	6
Product description and use.....	7
Overview of the item Conveyor Belt System .....	8
Operating data .....	9
Installation and environmental conditions.....	11
General preliminary work for setting up and commissioning the Conveyor Belt System .....	11
Flat Belt Conveyor 8 40 D.....	12
Frame of Flat Belt Conveyor 8 40 D .....	12
Drive assembly of Flat Belt Conveyor 8 40 D.....	12
Return assembly of Flat Belt Conveyor 8 40 D.....	15
Glide plate of Flat Belt Conveyor 8 40 D.....	17
Flat Conveyor Belt of Flat Belt Conveyor 8 40 D .....	19
Belt Support Set of Flat Belt Conveyor 8 40 D.....	21
Double Flat Belt Conveyor 8 40 D.....	23
Frame of Double Flat Belt Conveyor 8 40 D.....	23
Drive assembly of Double Flat Belt Conveyor 8 40 D.....	23
Return assembly of Double Flat Belt Conveyor 8 40 D.....	25
Glide plate of Double Flat Belt Conveyor 8 40 D .....	26
Flat Conveyor Belt of Double Flat Belt Conveyor 8 40 D.....	28
Synchronisation of Double Flat Belt Conveyor 8 40 D.....	30
Belt Support Set of Double Flat Belt Conveyor 8 40 D .....	32
Timing Belt Conveyor 8 40 D.....	34
Drive assembly of Timing Belt Conveyor 8 40 D.....	34
Return assembly of Timing Belt Conveyor 8 40 D.....	36
Entry/Output Timing Belt Guide Strip of Timing Belt Conveyor 8 40 D.....	37
Guide strip of Timing Belt Conveyor 8 40 D.....	37
Timing Belt of Timing Belt Conveyor 8 40 D.....	38
Belt Support Set of Timing Belt Conveyor 8 40 D.....	40
Double Timing Belt Conveyor 8 40 D.....	42
Frame of Double Timing Belt Conveyor 8 40 D.....	42
Drive assembly of Double Timing Belt Conveyor 8 40 D.....	42
Return assembly of Double Timing Belt Conveyor 8 40 D.....	44
Entry/Output Timing Belt Guide Strip of Double Timing Belt Conveyor 8 40 D.....	43
Guide strip of Double Timing Belt Conveyor 8 40 D.....	45
Timing Belt of Double Timing Belt Conveyor 8 40 D.....	45
Synchronisation of Double Timing Belt Conveyor 8 40 D.....	48
Belt Support Set of Double Timing Belt Conveyor 8 40 D .....	50
Drive elements.....	53
Bevel Gearbox D14/D11.....	55
Motor Fastening Set 8 40 D16 .....	56
Motor Fastening Set 8 40 D14 .....	56
Synchronising Set 8 40 .....	57
Synchroniser Shaft Cover Profile 8 40 .....	57
Fitting Motor AC D11 .....	58
Fitting Motor AC D16.....	61

Maintenance and inspection.....63  
 Spare parts list .....64  
 Disposal .....67  
 Warranty .....67  
 Development and documentation .....67

## Symbols, safety



Important information



Note! Failure to observe this safety instruction can result in material damage



Warning! Failure to observe this safety instruction is likely to result in material damage, serious injury or death



Danger! Failure to observe this safety instruction can result in material damage, serious injury or death



Caution! Failure to observe this safety instruction can result in material damage or injury



Maintenance



Observe directions for disposal



Observe directions for disposal

## General safety information

The details and information in this guide are provided for the purposes of describing the product and its assembly only. This information does not discharge users from the obligation to conduct their own assessments and checks. It is also important to bear in mind that our products are subject to a natural process of wear and ageing.

This guide contains important information that will enable you to use the product safely and appropriately. When this product is sold, rented out or otherwise passed on to another party, it must be handed over with this guide.

During assembly, operation and maintenance of the item Conveyor Belt System, it is important to ensure that all moving elements of the overall construction are secured to prevent unintentional movement. Parts that can make uncontrolled movements present a risk of injury.

You must therefore read and follow the safety instructions set out below.

- All work on and with the item Conveyor Belt System must be performed with “safety first” in mind.
- Take care when within the swivel range or working area of the moving overall construction if it is in motion or in use.
- Observe the regulations pertaining to accident prevention and environmental protection that apply in the country and place of work where the product is being used.
- Use only item products that are in perfect working order.

- Check the product for obvious defects.
- Use the belt conveyor technology only within the performance range described in the technical data.
- Ensure all the safety equipment associated with the product is present, properly installed and in full working order.
- Do not alter the position of safety equipment, circumvent it or render it ineffective.

The belt conveyor technology described here corresponds to the state of the art and takes into account the general principles of safety applicable at the time this assembly guide was published. Nevertheless, failure to observe the safety instructions and warning notices in this guide may result in personal injury and damage to property. We will assume no liability for any resulting damage or injury.

We reserve the right to make changes that represent technical advances.

Keep this guide in a place where it can be accessed by all users at any time. Observe the directions contained in the overarching user guide for a system. The general safety information applies to the entire lifecycle of the belt conveyor technology.

### 1. During transportation

Observe the handling instructions on the packaging. Until it is assembled, the product must be stored in its original packaging, protected from moisture and damage. Suspended loads can fall during transport if load-lifting attachments are inadequately dimensioned or incorrectly secured, thus potentially leading to serious injuries, including fatal injuries. Keep clear of suspended loads and use lifting gear with sufficient load-bearing capacity (see delivery paperwork for product weight). Carefully secure lifting gear and attach it only at sufficiently stable points. The packaging meets the requirements of all agreed methods of transportation. Avoid shocks and impacts. On receipt, immediately inspect all boxes and packaging for visible damage and check the delivery against the carrier's delivery note to ensure it is complete. Notify the supplier of any defects without delay. If deliveries are transported manually, ensure staff can reasonably be expected to lift and carry them. The belt conveyor system is to be stored in a dry place in its original packaging, and is to be protected against dirt and adverse weather conditions until it is assembled. Avoid exposure to extreme heat or cold. Also avoid excessive storage periods (we recommend a maximum of one year under climate-controlled conditions) and check prior to installation that the motor bearings and seals are in working order.

### 2. During operation

Ensure that only persons who have been authorised by the user have access to the immediate swivel range and operating area of the system. This also applies when the system is not in active use. It must not be possible to actuate moving parts unintentionally. The item Conveyor Belt System is not suitable for transporting people.

### 3. During cleaning

Do not use aggressive cleaning substances. Do not use a high-pressure cleaner for cleaning.

### 4. During maintenance and servicing work

Carry out the prescribed maintenance work at the intervals stipulated in the guide. Ensure that no fixings, connections or components are detached or loose. Secure moving parts during maintenance. Disconnect equipment from the power supply when carrying out maintenance work.

### 5. During disposal

Dispose of the product in accordance with the national and international regulations that apply in your country.

## Correct use

The Conveyor Belt System must be used in accordance with the technical data and safety requirements set out in this document. Such systems are used in a whole host of applications for transport purposes and to supply goods. Only indoor use is permitted. The system must not be operated outdoors.

The Conveyor Belt System is a partly completed machine as defined in Machinery Directive 2006/42/EC. It must not be operated until the partly completed machine is securely integrated into the overall system. Unsafe or inappropriate use runs a risk of serious injury caused by falling loads, crushing and cuts.

The basic safety provisions of the following rules and regulations have been taken into account:

- Machinery Directive 2006/42/EC – partly completed machine

The basic safety provisions of the following rules and regulations have been taken into account for electrical and electronic components:

- EMC Directive 2014/30/EU
- RoHS Directive 2011/65/EU, including the amendment to this Directive (EU 2015/863)

Internal company requirements and the regulations that apply in the country where the product is being used must be observed. No unauthorised design modifications or machining work should be carried out on the item Conveyor Belt System. We will assume no liability for any resulting damage or injury.

### Improper use

Improper use is defined as any use of the product for purposes other than those authorised in the user guide and under the definition of correct use. We will assume no liability for any resulting damage or injury.

The Conveyor Belt System must not be used to:

- Transport loads for which it was not designed or carry people
- Transport loose materials (e.g. sand, rubble, etc.)
- Transport hot or sharp-edged objects
- Provide structural support
- Climb or stand on

If you have any questions, please contact an item branch or distribution partner.

### Special safety instructions



To ensure satisfactory system operation and optimum performance, it is essential to familiarise operators and maintenance staff with the documentation from a very early stage.

- During positioning and operation, make sure no crushing, entrapment, cutting, impact or tripping hazards can arise that affect handling and the surrounding area.
- Check the Conveyor Belt System for corrosion, wear, cracks, deformation, etc. on a regular basis and whenever starting it up. Only undamaged equipment can be taken into service.
- In the case of structural or electrical damage, immediately shut down the Conveyor Belt System and contact an appropriately qualified person, such as a mechanic or electrician.
- Do not use the Conveyor Belt System in rooms with a high dust content, humidity or temperature (if you have any questions, please contact an item branch or distribution partner).
- The immediate vicinity of the Conveyor Belt System is considered a safety zone. This safety zone must be kept clear during operation to prevent damage to material and buildings and avoid personal injury.
- During operation, ensure no objects, clothing or parts of the body are pulled into the item Conveyor Belt System.
- During operation, it is essential that no-one is located underneath the Conveyor Belt System or the safety zone designated by the operator.
- Never cover the Motor's cooling zone, and ensure sufficient ventilation.
- Liquids must not be allowed to penetrate electrical components. If this occurs, disconnect the power supply.
- Disconnect the Conveyor Belt System from the mains when transporting or repositioning it.
- The Conveyor Belt System must be disconnected from the mains for cleaning, maintenance and servicing.
- All assembly, commissioning and electrical installation work must be carried out by trained, qualified persons only.
- The Conveyor Belt System should be used as instructed by the manufacturer, and only for the tasks/media specified in the order and order confirmation.



- Planners, manufacturers, operators and users are responsible for proper and safe assembly and for safe operation. Safety equipment must not be removed, circumvented or deactivated.
- To prevent crushing and cuts, nearby objects should be kept at a minimum distance of 50 mm.
- Inappropriate use of the Conveyor Belt System can pose hazards to people and equipment. The product warranty is valid only when the product is used as intended.
- A mobile Conveyor Belt System must be inspected for stability and made stable. Extreme gradients and high, uncontrollable speeds must be avoided.
- The Conveyor Belt System must not be used in environments where there is a risk of explosion.
- Watch out for the risk of crushing during operation. If it is impossible to prevent this hazard, take the necessary measures to make the danger zone inaccessible.
- Observe internal company requirements and the laws in the country where the system is being used.

### Personnel qualifications

Assembly, commissioning, operation, disassembly and maintenance work (including servicing and care) require an adequate knowledge of mechanical engineering and an understanding of the relevant technical terminology. To ensure operational safety, these activities must therefore be carried out by a qualified or trained person.

Only authorised, qualified persons are permitted to commission the equipment and carry out work on its electrical components.

You may only use and carry out maintenance on the Conveyor Belt System if:

- The system has been integrated properly and safely into the working environment
- You have carefully read and understood the guide
- You are mentally and physically capable of doing so
- You are authorised to do so by your organisation or employer
- You are using only original equipment from the manufacturer



Caution! The operator is responsible for ensuring proper and safe operation.

## Product description and use

Conveyor belts ensure a continuous flow of materials without any manual intervention by staff. Depending on their design, they can transport products either in a random sequence or pre-sorted on workpiece carriers or in containers. Both lightweight individual parts and heavy assemblies can be conveyed in this way, with the transport speed being adapted to the requirements of the work process.

Specialised components and standard profiles in thousands of possible combinations provide you with exactly the right system, whatever goods you need to transport:

- Individual or parallel Flat Conveyor Belts and Timing Belts
- Double Flat Belt Conveyors and Timing Belt Conveyors up to 2400 mm wide and 6000 mm long
- Electric motors with integrated or separate gearbox

Compatible with the components in the item Building Kit System, the item Conveyor Belt System is easy to integrate into machinery, guards and enclosures.

The item Conveyor Belt System also benefits from low maintenance requirements and a long service life.

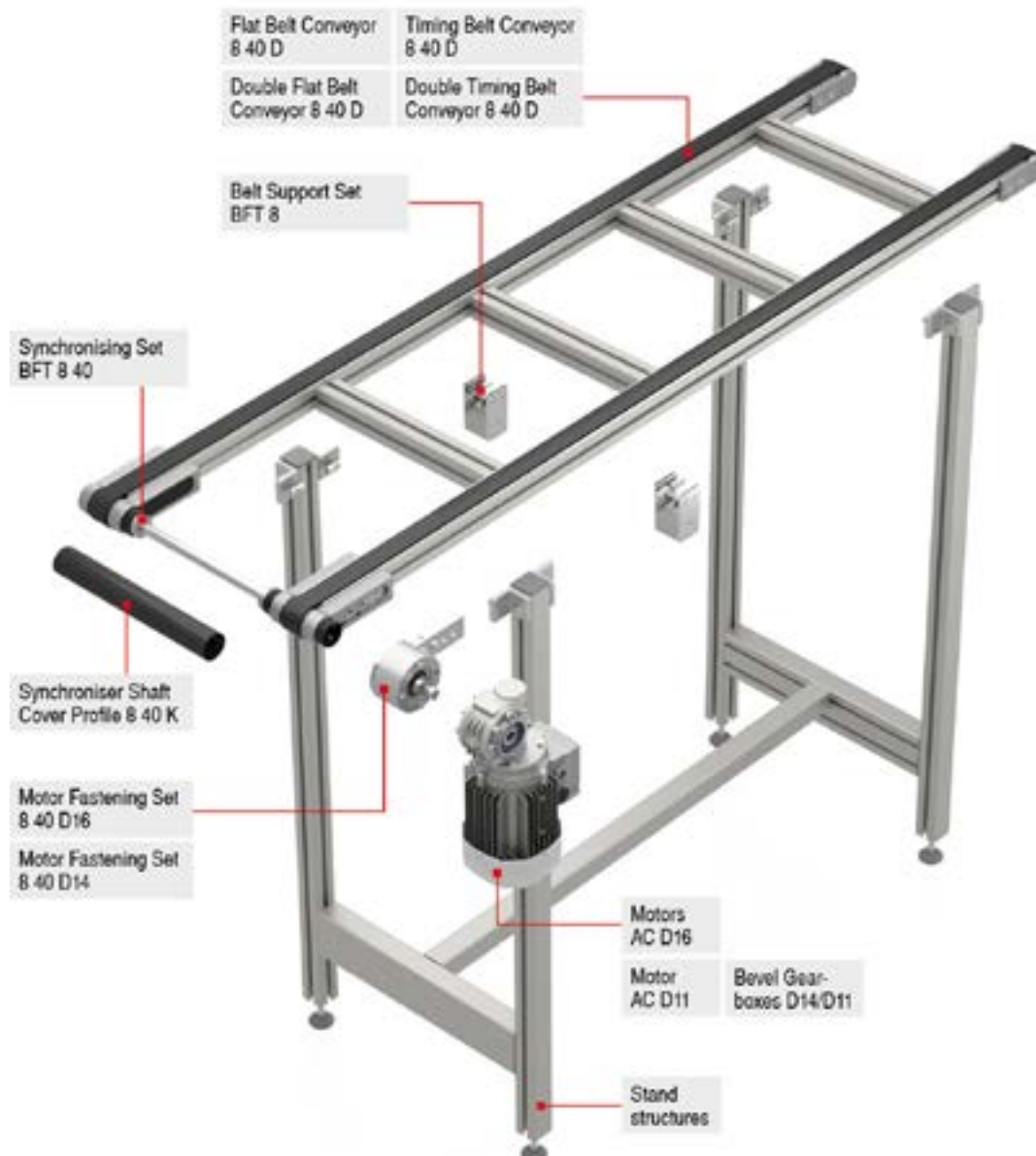

## Overview of the item Conveyor Belt System



### Flat Belt Conveyor 8 40 D

#### Continuous Flat Conveyor Belt

- In eight widths up to 400 mm
- For goods and containers, even ones with irregular bases
- Maximum line load up to 25 kg/m
- Accumulating belts available
- Gradient up to 20°
- Choice of two direct drives
- Conveyor sections 500 to 6000 mm long
- Conveyor belt speed of 2.5 to 28.9 m/min



### Double Flat Belt Conveyor 8 40 D

#### Parallel Flat Conveyor Belts

- Choice of 40 or 80 mm conveying width
- Total width up to 2400 mm
- For transporting goods that are inherently stable
- Maximum line load 25 kg/m
- Accumulating belts available
- Gradient up to 20°
- Choice of two direct drives
- Conveyor sections 500 to 6000 mm long
- Conveyor belt speed of 2.5 to 28.9 m/min



### Timing Belt Conveyor 8 40 D

#### Reinforced Timing Belt

- Choice of 40 or 80 mm conveying width
- For transporting heavy objects
- Maximum line load 25 kg/m
- Accumulating belts available
- Gradient up to 20°
- Choice of two direct drives
- Conveyor sections 500 to 6000 mm long
- Conveyor belt speed of 2.8 to 31.4 m/min





### Double Timing Belt Conveyor 8 40 D

#### Parallel, reinforced Timing Belts

- Choice of 40 or 80 mm conveying width
- Total width up to 2400 mm
- For transporting heavy loads
- Runs true even under lateral forces
- Maximum line load 25 kg/m
- Accumulating belts available
- Gradient up to 20°
- Choice of two direct drives
- Conveyor sections 500 to 6000 mm long
- Conveyor belt speed of 2.8 to 31.4 m/min

## Operating data

### Flat Belt Conveyor 8 40 D:

Conveying system	Belt speed	Max. total load (non-accumulating)	Max. total load (accumulating)
Flat Belt Conveyor 8 40 D -40	2,5 - 28,9 m/min	15 kg	4 kg
Flat Belt Conveyor 8 40 D -80	2,5 - 28,9 m/min	27 kg	8 kg
Flat Belt Conveyor 8 40 D -120	2,5 - 28,9 m/min	38 kg	12 kg
Flat Belt Conveyor 8 40 D -160	2,5 - 28,9 m/min	51 kg	17 kg
Flat Belt Conveyor 8 40 D -200	2,5 - 28,9 m/min	63 kg	22 kg
Flat Belt Conveyor 8 40 D -240	2,5 - 28,9 m/min	75 kg	26 kg
Flat Belt Conveyor 8 40 D -320	2,5 - 28,9 m/min	100 kg	35 kg
Flat Belt Conveyor 8 40 D -400	2,5 - 28,9 m/min	100 kg	45 kg

- Axle spacing: 500 - 6000 mm
- Total conveyor width: 40, 80, 120, 160, 200, 240, 320 or 400 mm
- Max. line load: 25 kg/m
- Drive orientation: 0°, 90°, 180° or 270°

**Double Flat Belt Conveyor 8 40 D:**

Conveying system	Belt speed	Max. total load (non-accumulating)	Max. total load (accumulating)
Double Flat Belt Conveyor 8 40 D -40	2,5 - 28,9 m/min	30 kg	8 kg
Double Flat Belt Conveyor 8 40 D -80	2,5 - 28,9 m/min	55 kg	17 kg

- Axle spacing: 500 - 6000 mm
- Total conveyor width: 172 - 2400 mm
- Max. line load: 25 kg/m
- Drive orientation: 0°, 90°, 180° or 270°

**Timing Belt Conveyor 8 40 D:**

Conveying system	Belt speed	Max. total load (non-accumulating)	Max. total load (accumulating)
Timing Belt Conveyor 8 40 D -40	2,8 - 31,4 m/min	90 kg	45 kg
Timing Belt Conveyor 8 40 D -80	2,8 - 31,4 m/min	100 kg	50 kg

- Axle spacing: 500 - 6000 mm
- Total conveyor width: 40 or 80 mm
- Max. line load: 25 kg/m
- Drive orientation: 0°, 90°, 180° or 270°

**Double Timing Belt Conveyor 8 40 D:**

Conveying system	Belt speed	Max. total load (non-accumulating)	Max. total load (accumulating)
Double Timing Belt Conveyor 8 40 D -40	2,8 - 31,4 m/min	90 kg	45 kg
Double Timing Belt Conveyor 8 40 D -80	2,8 - 31,4 m/min	100 kg	50 kg

- Axle spacing: 500 - 6000 mm
- Total conveyor width: 172 - 2400 mm
- Max. line load: 25 kg/m
- Drive orientation: 0°, 90°, 180° or 270°

## Installation and environmental conditions



Air pressure > 84 kPa, equivalent to an altitude of < 1400 m above sea level. At altitudes > 1400 m, load values are to be reduced by 15 percent.

Appropriate components can be selected and installed to ensure the Conveyor Belt System is suitable, under certain circumstances, for use in areas where electrostatic charges pose hazards. We recommend you consult your item representative or distribution partner.

The Conveyor Belt System is intended as a permanent fixture to be used in an area that is protected from the weather.

- The area should be free from mould and fungus and show no traces of rodents or other pests.
- Do not set up or use in close proximity to industrial plants that produce chemical emissions.
- Do not set up or use near sources of sand or dust.
- Do not install or use in an area that is regularly exposed to high-energy surges such as those caused by presses or heavy machinery, for example.
- The system is resistant to many of the substances usually encountered in the production area, such as water, mineral oil, grease and detergents. If you are in any doubt regarding resistance to certain chemicals such as test oil, alloyed oils, aggressive cleaning substances, solvents or brake fluid, we advise that you consult your specialist representative.
- Avoid long periods of contact with highly acidic or alkaline substances.
- If using in very salty air, consult your item representative or distribution partner.

To operate properly, the Conveyor Belt System must be level. Setting it up and/or starting it up incorrectly causes malfunctions. There is a possibility of the Conveyor Belt System being damaged and its service life being shortened.

Other factors that can affect the service life:

- When setting up the Conveyor Belt System, ensure the frame is level, perpendicular and axially parallel.
- Avoid flexural and torsional loads.
- Do not use the conveyor belt in combination with other guiding elements (avoid forced guidance).
- Adjust the gap between the frame stanchions to suit the anticipated loads.

## General preliminary work for setting up and commissioning the Conveyor Belt System

Whatever kind of belt conveyor technology you choose, you need to start by machining the profile ends where the drive will be located. At the end of the profile where the Motor will be fitted, countersink the core bores and then tap an M8x20 thread.



## Flat Belt Conveyor 8 40 D

Flat Belt Conveyor 8 40 D is available in eight widths up to 400 mm and in lengths of up to 6000 mm. The continuous belt efficiently transports all kinds of goods and containers, even ones with irregular bases.

## Frame of Flat Belt Conveyor 8 40 D



Caution! Before starting work on the belt conveyor, the basic frame needs to be aligned. The two profiles running parallel to one another must be perfectly aligned. Any parallel misalignment between the cut edges should be less than 0.1 mm.



Note! The basic frame's perpendicularity and parallelism should be checked using a measuring square.

## Drive assembly of Flat Belt Conveyor 8 40 D

Screw the two flat-head Hexagon Socket Head Cap Screws M8x14 all the way in. These screws help secure a tensioning hook so that the drive assembly can still be adjusted at the end of the assembly process.



The drive assembly first needs to be put together and fastened in place.



To do so, insert the shaft clamping ring into the half of the Drive Unit that will be located opposite the motor. Then, on what will be the half connected to the motor, push the positioning ring from the inside through to the fastening and clip it into place.



Note! At the end of this process, the positioning ring is facing outwards.



Next, press the Drive Pulley bearings into the Drive Unit by hand and then, as a ready-made assembly, fit the two halves of the Drive Unit to the sides of the profiles, slotting them into the Line 8 grooves up to the stop and then tightening by hand. When slotting in the Drive Unit halves, ensure the tensioning hook is positioned correctly in its final position and is not twisted or jammed. The flat-head Hexagon Socket Head Cap Screws M8x14 are used for this purpose.

Leave final fastening until the belt has been tensioned.





Note! The item lettering is at the bottom and the axial offset from the centre of the profile to the centre of the drive assembly is 1 mm. This is vital to minimise friction.

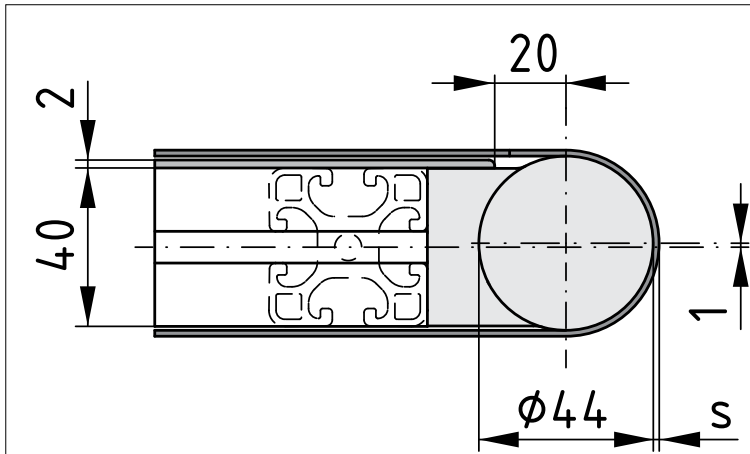



## Return assembly of Flat Belt Conveyor 8 40 D

The return assembly is assembled in a similar way to the drive assembly. The profile bores at this end do not need to be machined.



Before fitting the return assembly to the profile, slot a Fine Adjuster 8 into the groove on the side of each of the Line 8 profiles.

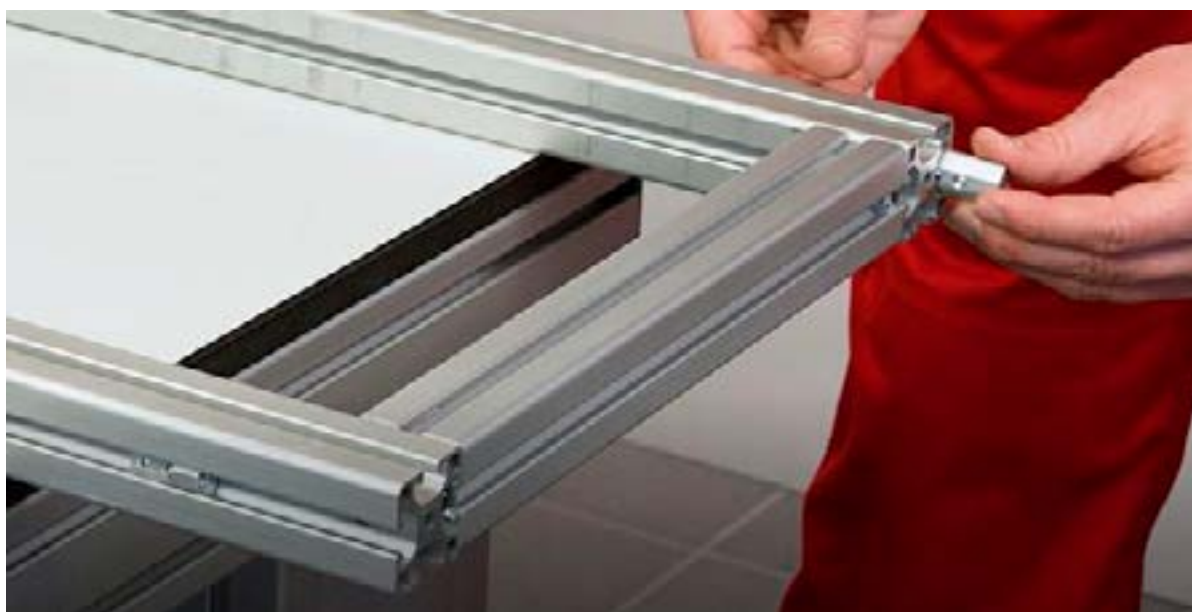

Press the Return Pulley firmly into place in the Return Unit by hand.



Note! The item lettering is at the bottom and the axial offset from the centre of the profile to the centre of the return assembly is 1 mm. This is vital to minimise friction.



Following preliminary assembly, slot the return assembly into the groove on the side of the profiles and then tighten.

$M_T = 10 \text{ Nm}$

Slide the Fine Adjusters firmly up against the return assembly and secure in place using grub screws DIN 916-M6x12.

$M_T = 4 \text{ Nm}$



## Glide plate of Flat Belt Conveyor 8 40 D

The length of the glide plate is determined in advance with the help of the configurator. Glide plates are dimensioned based on the configurator's calculations and are supplied ready to install.

The glide plates are pre-drilled for the countersunk screws. The countersink positions are determined in the configurator and are aligned with the frame and the positions of the cross profiles. Start by laying the plate on the profiles and centring it in relation to the long sides. Mark the positions of the drilled holes on the profile for subsequent positioning of the T-Slot Nuts.



Next, remove the glide plate, position the T-Slot Nuts, replace the plate and tighten the screw fixings loosely so that the plate can still move.



After centring the plate in relation to the long sides, also align it with the return assembly. The distance between the axis of the Return Pulley and the edge of the plate is 20 mm. To achieve this, slide the plate to the edge of the guard on the Return Unit so that only a small gap remains between the plate and the Return Pulley



Then tighten the countersunk screws securely.  $M_T = 5 \text{ Nm}$

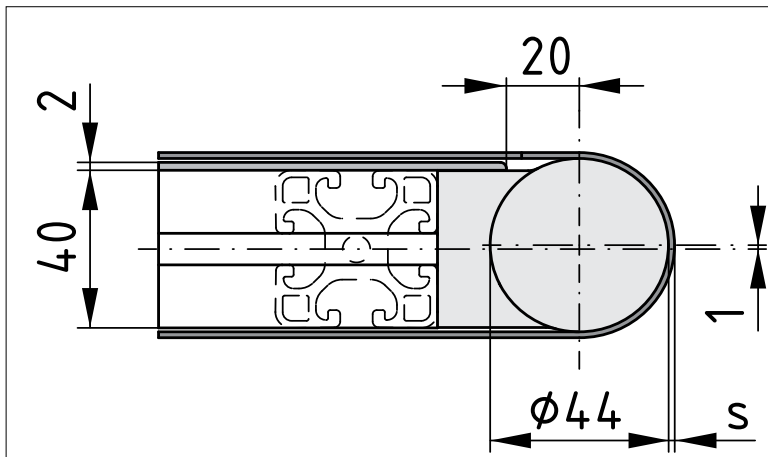

## Flat Conveyor Belt of Flat Belt Conveyor 8 40 D

Place the pre-welded Flat Conveyor Belt over the pulleys and the profile.



Note! If possible, lay the profile on its side and then wrap the belt around the profile.

Turn the profile back over. To tension the belt, the return run on the underside must be able to move freely so as not to obstruct this process. To apply the necessary pre-tensioning force, first loosen the Drive Unit again.

Correct belt tensioning is vital to ensure the belt conveyor system works properly. The value to which the Flat Conveyor Belt needs to be tensioned can be obtained from the table below. This depends on the conveyor system's nominal width and the type of belt.

Nominal width [mm]	Flat Conveyor Belt PVC, accumulating Pre-tensioning [%]	Flat Conveyor Belt PUR ESD, accumulating Pre-tensioning [%]	Flat Conveyor Belt PVC, non-accumulating Pre-tensioning [%]
40	0,5	0,5	0,5
80	0,5	0,5	0,5
120	0,5	0,5	0,5
160	0,5	0,5	0,5
200	0,5	0,5	0,5
240	0,5	0,5	0,5
320	0,5	0,5	0,4
400	0,4	0,4	0,3



The belt tension must be monitored during the tensioning process. This is done with the help of a steel ruler. The Flat Conveyor Belt must be able to move freely and must not be clamped in place anywhere. Use the steel ruler to mark a specific distance on the belt. A distance of e.g. 1000 mm is recommended, as this makes the percentage elongation specified in the table easier to check and read off.



Turn the tensioning screws to tension the Flat Conveyor Belt and achieve an elongation of e.g. 0.5 percent, that is to say 5/1000ths of its total length. In the example with a distance of 1000 mm marked, the necessary pre-tensioning is achieved when the marks have moved a further 5 mm apart, to a total of 1005 mm. In the case of 0.4 percent or 0.3 percent elongation, the correct pre-tensioning is achieved when the distance between the marks is 1004 mm and 1003 mm respectively.



Once the required belt tension has been achieved, ensure the Flat Conveyor Belt is running straight by readjusting the tensioning screws on the drive assembly. To do so, move the belt by hand in one direction. If the Flat Conveyor Belt is drifting to the right, carefully retighten the right-hand screw of the tensioning mechanism until the belt looks as though it is running straight. If it is drifting to the left, carefully adjust the left-hand tensioning screw.

Once you have adjusted the pre-tensioning and straight running, tighten the drive assembly's fastening screws to the final tightness.

$$M_T = 10 \text{ Nm}$$

Fine Adjuster Set 8, which has already been fitted, can be used to fine-tune straight running.

If the belt is not running straight at the return end, loosen the return assembly on the side towards which the belt is drifting and readjust the tensioning screw of Fine Adjuster Set 8 until the belt is running perfectly. Then retighten using the established tightening torques.



Note! Fine Adjuster Set 8 should be used for minor, final straight-running adjustments only. Use the tensioning mechanism at the drive end for the main adjustment.



Caution! After a test run lasting approx. three hours, check the Flat Conveyor Belt's straight running and tension.

### Belt Support Set of Flat Belt Conveyor 8 40 D

Flat Conveyor Belts above a certain length need to be supported to avoid sagging and prevent wear.



Caution! Gaps exceeding 5 mm create danger zones where limbs or tools can be pulled into the system.

The Belt Support Set needs to be fitted for this purpose. Its width depends on the width of the conveyor system and is set accordingly by the configurator. Since the process remains the same regardless of the width, it is described here using a representative belt support for a width of 80 mm.



The first step is to fit the deep groove ball bearing to the flat brackets. On these brackets, pre-fit a countersunk screw and a threaded bush for securing (countering) the screw when tightening.



Next, use a mallet to carefully hammer the bearings into both ends of Tube D30. Then use self-tapping screws to assemble the flat brackets with Tube D30, protected by Conduit Profile 8 40x40 SE.

$M_T = 2 \text{ Nm}$

Prepare the brackets for fastening to the side of the conveyor belt's Line 8 profiles and screw into place.

$M_T = 10 \text{ Nm}$



Note! When using Belt Support Sets:

For systems over 2000 mm long, always attach these evenly spaced underneath the Flat Belt Conveyor.

Conveyor systems up to 2000 mm long: No belt support system

Conveyor systems more than 2000 mm and up to 4000 mm long: One belt support halfway along underneath the system

Conveyor systems more than 4000 mm and up to 6000 mm long: Two belt supports evenly spaced over the length

The T-Slot Nuts provided are used for fastening to the Line 8 profile.



## Double Flat Belt Conveyor 8 40 D

Double Flat Belt Conveyor 8 40 D is available in two belt widths – 40 mm and 80 mm – and in lengths of up to 6000 mm. The total width of the synchronised belts can be anything up to 2400 mm. The synchronised belts help to move inherently stable products efficiently from A to B.

## Frame of Double Flat Belt Conveyor 8 40 D



Caution! Before starting work on the Double Flat Belt Conveyor, the basic frame needs to be aligned. The two belts running parallel to one another must run in perfect alignment. Any parallel misalignment between the cut edges should be less than 0.1 mm.



Note! The basic frame's perpendicularity and parallelism should be checked using a measuring square.

## Drive assembly of Double Flat Belt Conveyor 8 40 D

Screw the two flat-head Hexagon Socket Head Cap Screws M8x14 all the way in. These screws help secure a tensioning hook so that the drive assembly can still be adjusted at the end of the assembly process.



The drive assembly first needs to be put together and fastened in place.





To do so, insert the shaft clamping ring into the half of the Drive Unit that will be located opposite the motor. Then, on what will be the half connected to the motor, push the positioning ring from the inside through to the fastening and clip it into place.



Note! At the end of this process, the positioning ring is facing outwards.



Next, press the Drive Pulley bearings into the Drive Unit by hand and then, as a ready-made assembly, fit the two halves of the Drive Unit to the sides of the profiles, slotting them into the Profile 8 40x40 or Profile 8 80x40 grooves up to the stop and then tightening by hand.

When slotting in the Drive Unit halves, ensure the tensioning hook is positioned correctly in its final position and is not twisted or jammed. The flat-head Hexagon Socket Head Cap Screws M8x14 are used for this purpose.

Leave final fastening until the belt has been tensioned.

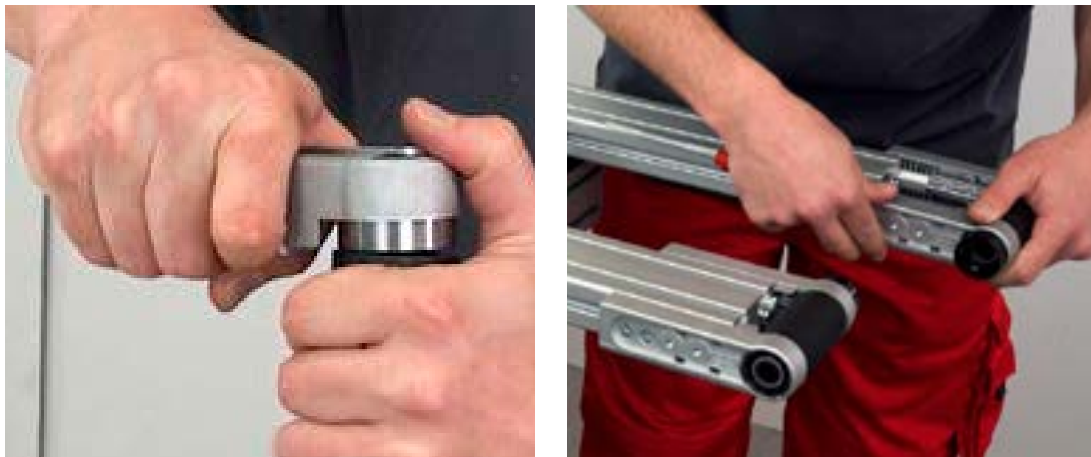

Note! The item lettering is at the bottom and the axial offset from the centre of the profile to the centre of the drive assembly is 1 mm. This is vital to minimise friction.



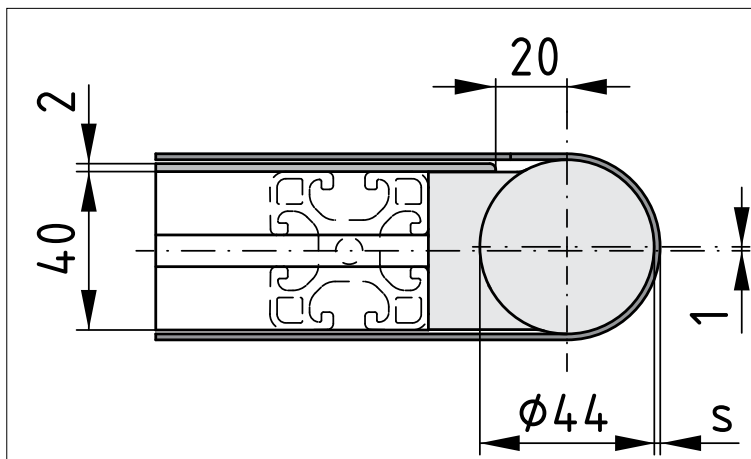

**Return assembly of Double Flat Belt Conveyor 8 40 D**

The return assembly is assembled in a similar way to the drive assembly. The profile bores at this end do not need to be machined.



Before fitting the return assembly to the profile, slot a Fine Adjuster 8 into the groove on the side of each of the Line 8 profiles.



Press the Return Pulley firmly into place in the Return Unit by hand.



Note! The item lettering is at the bottom and the axial offset from the centre of the profile to the centre of the return assembly is 1 mm. This is vital to minimise friction.



Following preliminary assembly, slot the return assembly into the grooves on the side of Profile 8 40x40 or Profile 8 80x40 and then tighten.

$M_T = 10 \text{ Nm}$

Slide the Fine Adjusters firmly up against the return assembly and secure in place using grub screws DIN 916-M6x12.

$M_T = 4 \text{ Nm}$

### Glide plate of Double Flat Belt Conveyor 8 40 D

The length of the glide plate is determined in advance with the help of the configurator. Glide plates are dimensioned based on the configurator's calculations and are supplied ready to install.

The glide plates are pre-drilled for the countersunk screws. The countersink positions are determined in the configurator and are aligned with the frame and the positions of the cross profiles. Start by laying the plate on the profiles and centring it in relation to the long sides. Mark the positions of the drilled holes on the profile for subsequent positioning of the T-Slot Nuts.



Next, remove the glide plate, position the T-Slot Nuts, replace the plate and tighten the screw fixings loosely so that the plate can still move.

After centring the plate in relation to the long sides, also align it with the return assembly. The distance between the axis of the Return Pulley and the edge of the plate is 20 mm. To achieve this, slide the plate to the edge of the guard on the Return Unit so that only a small gap remains between the plate and the Return Pulley.



Then tighten the countersunk screws securely.  $M_T = 5 \text{ Nm}$

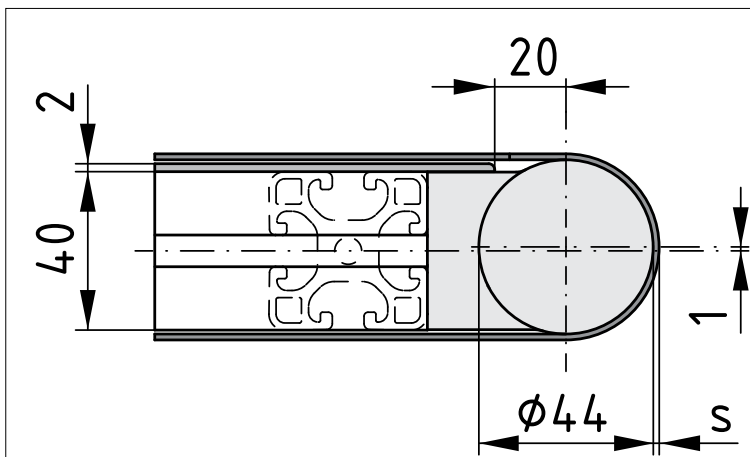

## Flat Conveyor Belt of Double Flat Belt Conveyor 8 40 D

Place the pre-welded Flat Conveyor Belt over the pulleys and the profile.



Note! If possible, lay the profile on its side and then wrap the belt around the profile.

Turn the profile back over. To tension the belt, the return run on the underside must be able to move freely so as not to obstruct this process. To apply the necessary pre-tensioning force, first loosen the Drive Unit again.

Correct belt tensioning is vital to ensure the belt conveyor system works properly. A pre-tension/elongation of 0.5 percent must be applied to the Flat Conveyor Belts of a Double Flat Belt Conveyor.



The belt tension must be monitored during the tensioning process. This is done with the help of a steel ruler. The Flat Conveyor Belt must be able to move freely and must not be clamped in place anywhere. Use the steel ruler to mark a specific distance on the belt. A distance of e.g. 1000 mm is recommended, as this makes the elongation of 0.5 percent easier to check and read off.

Turn the tensioning screws to tension the Flat Conveyor Belt and achieve an elongation of 0.5 percent, that is to say

5/1000ths of its total length. In the example with a distance of 1000 mm marked, the necessary pre-tensioning is achieved when the marks have moved a further 5 mm apart, to a total of 1005 mm.



Once the required belt tension has been achieved, ensure the Flat Conveyor Belt is running straight by readjusting the tensioning screws on the drive assembly. To do so, move the belt by hand in one direction. If the Flat Conveyor Belt is drifting to the right, carefully retighten the right-hand screw of the tensioning mechanism until the belt looks as though it is running straight. If it is drifting to the left, carefully adjust the left-hand tensioning screw.



Once you have adjusted the pre-tensioning and straight running, tighten the drive assembly's fastening screws to the final tightness.  $M_T = 10 \text{ Nm}$

Fine Adjuster Set 8, which has already been fitted, can be used to fine-tune straight running.

If the belt is not running straight at the return end, loosen the return assembly on the side towards which the belt is drifting and readjust the tensioning screw of Fine Adjuster Set 8 until the belt is running perfectly. Then retighten using the established tightening torques.





Note! Fine Adjuster Set 8 should be used for minor, final straight-running adjustments only. Use the tensioning mechanism at the drive end for the main adjustment.



Caution! After a test run lasting approx. three hours, check the Flat Conveyor Belt's straight running and tension.

### Synchronisation of Double Flat Belt Conveyor 8 40 D

A Double Flat Belt Conveyor must be synchronised. The drive assemblies have been fitted with their positioning aids facing inward. The third positioning ring is located at the motor side.



First, screw the expanding hub coupling halves that have a shaft to the inside of each drive assembly.  $M_T = 9 \text{ Nm}$



Next, slide the remaining coupling halves onto the synchroniser tube and, starting at one end, align the coupling half with its counterpart and press both halves firmly together. Then push the coupling half on the other end of the tube into its counterpart and press both halves firmly together.



Once the synchroniser tube is sitting between the drive assemblies without any play, screw the couplings firmly to the synchroniser tube.  $M_T = 4 \text{ Nm}$



Caution! Rotating shaft. Spread open a Synchroniser Shaft Cover Profile 8 40 and wrap it around the synchroniser tube. Then use the Safety Seal to seal the safety cover.





Caution! Once the synchroniser tube cover has been fitted, the seal must be stuck on to seal it. Operation is permitted only if the seal is undamaged.

### Belt Support Set of Double Flat Belt Conveyor 8 40 D

Flat Conveyor Belts above a certain length need to be supported to avoid sagging and prevent wear. Construction kits for various belt widths are available for this purpose.



Caution! Gaps exceeding 5 mm create danger zones where limbs or tools can be pulled into the system.

The Belt Support Set needs to be fitted for this purpose.



The first step is to fit the deep groove ball bearing to the flat brackets. On these brackets, pre-fit a countersunk screw and a threaded bush for securing (countering) the screw when tightening.



Next, use a mallet to carefully hammer the bearings into both ends of Tube D30. Then use self-tapping screws to assemble the flat brackets with Tube D30, protected in Conduit Profile 8 40x40 SE.



$M_T = 2 \text{ Nm}$

Prepare the brackets for fastening to the side of the conveyor belt's Line 8 profiles and screw into place.

$M_T = 10 \text{ Nm}$



Note! When using belt supports:

For systems 2000 mm long or more, always attach these evenly spaced underneath the Flat Belt Conveyor.

Conveyor systems up to 2000 mm long: No belt support system

Conveyor systems more than 2000 mm and up to 4000 mm long: One belt support halfway along underneath the system

Conveyor systems more than 4000 mm and up to 6000 mm long: Two belt supports evenly spaced over the length

The T-Slot Nuts provided are used for fastening to the Line 8 profile.



## Timing Belt Conveyor 8 40 D

Timing Belt Conveyor 8 40 D is available in two belt widths – 40 mm and 80 mm – and in lengths of up to 6000 mm. The durable Timing Belt with integrated steel wires ensures non-slip transport of even heavy objects.

## Drive assembly of Timing Belt Conveyor 8 40 D



Screw the two flat-head Hexagon Socket Head Cap Screws M8x14 all the way in. These screws help secure a tensioning hook so that the drive assembly can still be adjusted at the end of the assembly process.



The drive assembly first needs to be put together and fastened in place.

To do so, insert the shaft clamping ring into the half of the Drive Unit that will be located opposite the motor. Then, on what will be the half connected to the motor, push the positioning ring from the inside through to the fastening and clip it into place.



Note! At the end of this process, the positioning ring is facing outwards.



Next, press the Drive Pulley bearings into the Drive Unit by hand and then, as a ready-made assembly, fit the two halves of the Drive Unit to the sides of the profiles, slotting them into the Profile 8 40x40 or Profile 8 80x40 grooves up to the stop and then tightening by hand. When slotting in the Drive Unit halves, ensure the tensioning hook is positioned correctly in its final position and is not twisted or jammed. The flat-head Hexagon Socket Head Cap Screws M8x14 are used for this purpose. Leave final fastening until the Timing Belt has been tensioned.



Note! The item lettering is at the bottom and the axial offset from the centre of the profile to the centre of the drive assembly is 1 mm. This is vital to minimise friction.

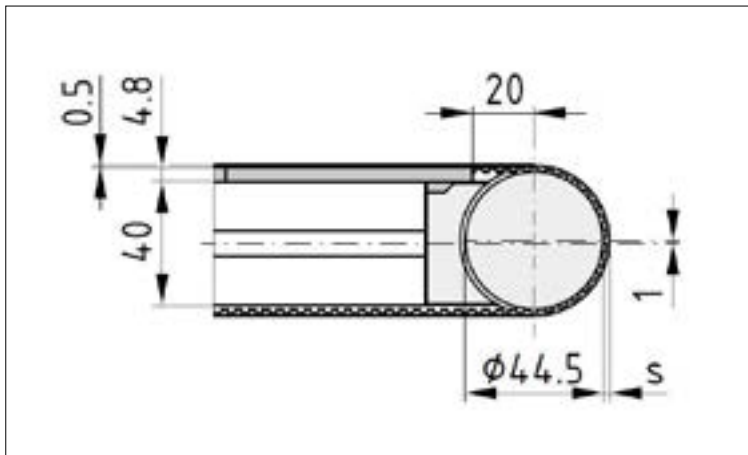

## Return assembly of Timing Belt Conveyor 8 40 D

The return assembly is assembled in a similar way to the drive assembly. The profile bores at this end do not need to be machined.



Press the Return Pulley firmly into place in the Return Unit by hand.



Following preliminary assembly, slot the return assembly into the grooves on the side of Profile 8 40x40 or Profile 8 80x40 and then tighten.  $M_T = 10 \text{ Nm}$



Note! The item lettering is at the bottom and the axial offset from the centre of the profile to the centre of the return assembly is 1 mm. This is vital to minimise friction.

## Entry/Output Timing Belt Guide Strip of Timing Belt Conveyor 8 40 D

Insert the two double T-Slot Nuts into the profile grooves.

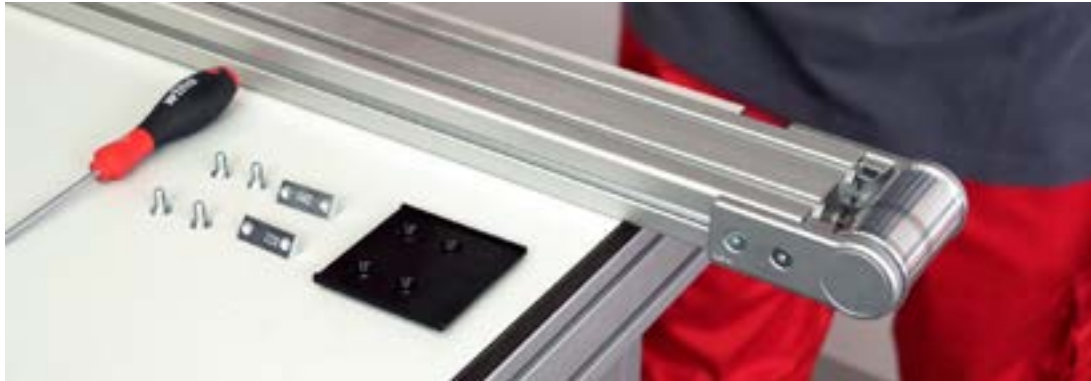

Then screw on the plastic panel loosely, align it and slide it towards the Return Pulley, leaving a gap of approx. 2 mm (distance from edge of plastic to axis of rotation: 20 mm).



Fit the entry/output guide strip at the drive end in exactly the same way. The final position is established once the guide strip has been fitted, after the next assembly step.



Note! Take care not to damage the plastic when subsequently tightening to the required torque.

$$M_T = 4 \text{ Nm}$$

## Guide strip of Timing Belt Conveyor 8 40 D

The length of the Timing Belt Guide Strip is determined in advance with the help of the configurator. However, this length can also be determined by measuring the distance between the entry and output guides. The guide strips have an uncut length of 2 m and can easily be fitted end to end.

When inserting, start at the entry/output of the return end. Simply press the guide strip into the groove and clip it into place. The guide strips are 40 mm wide and are installed side by side in the case of a Profile 8 80x40.



Note! There is a right-hand and a left-hand side! The raised edge of the strip must face outwards.



Recommendation! Cut to size using a saw with a fence, because the cut edge must be square. Multi-Purpose Pliers can be used in theory, but the cut is not sufficiently precise.

### Timing Belt of Timing Belt Conveyor 8 40 D

Place the pre-welded Timing Belt over the pulleys and the profile.



Note! If possible, position the profile on its side and wrap the Timing Belt around the profile.

Turn the profile back over. To tension the Timing Belt, the return run on the underside must be able to move freely so as not to obstruct this process. Loosen the drive assembly to enable the Timing Belt to be tensioned.



Caution! Precise and even belt tensioning is vital to ensure the belt conveyor system works properly.



Pre-tension the Timing Belts to achieve an elongation of 0.1 percent. The drive assembly's tensioning screws help with pre-tensioning. These screws must be tightened evenly and alternately.





The Timing Belt tension must be monitored during the tensioning process. There are various ways of doing this, e.g. using a frequency analyser or a steel ruler.



The frequency analyser determines the pre-tensioning value based on the vibration frequency of a defined section of the Timing Belt when it is struck. At a measuring distance of 0.5 m (spacing of the cylindrical pins supplied with the frequency analyser underneath the Timing Belt), a frequency of 50 Hz indicates the necessary pre-tensioning of 0.1 percent.



A steel ruler can also be used to check the Timing Belt tension. The Timing Belt must be able to move freely and must not be clamped in place anywhere. Use the steel ruler to mark a specific distance on the belt. A distance of e.g. 1000 mm is recommended, as this makes the elongation of 0.1 percent easier to check and read off.

Turn the tensioning screws to tension the belt and achieve an elongation of 0.1 percent, that is to say 1/1000th of its total length. In the example with a distance of 1000 mm marked, the necessary pre-tensioning is achieved when the marks have moved 1001 mm apart.

Once the required tension has been achieved, ensure the Timing Belt is running straight by readjusting the drive assembly's tensioning screws. To do so, move the belt by hand in one direction. If the Timing Belt is drifting to the right, against the flanged pulley or guide strip, carefully retighten the right-hand screw of the tensioning mechanism until the belt looks as though it is running straight. If it is drifting to the left, carefully adjust the left-hand tensioning screw.

Once you have adjusted the pre-tensioning and straight running, tighten the drive assembly's fastening screws to the final tightness.  $M_T = 10 \text{ Nm}$



Caution! After a test run lasting approx. three hours, check the belt's straight running and tension.

### Belt Support Set of Timing Belt Conveyor 8 40 D

Timing Belts above a certain length need to be supported to avoid sagging and reduce wear.

Caution! Gaps exceeding 5 mm create danger zones where limbs or tools can be pulled into the system.



The Belt Support Set needs to be fitted for this purpose.



The first step is to fit the deep groove ball bearing to the flat brackets. On these brackets, pre-fit a countersunk screw and a threaded bush for securing (countering) the screw when tightening.





Next, use a mallet to carefully hammer the bearings into both ends of Tube D30. Then use self-tapping screws to assemble the flat brackets with Tube D30, protected in Conduit Profile 8 40x40 SE.

$M_T = 2 \text{ Nm}$

Prepare the brackets for fastening to the side of the conveyor belt's Line 8 profiles and screw into place.

$M_T = 10 \text{ Nm}$



Note! When using belt supports:

For systems 2000 mm long or more, always attach these evenly spaced underneath the conveyor system.

Conveyor systems up to 2000 mm long: No belt support system

Conveyor systems more than 2000 mm and up to 4000 mm long: One belt support halfway along underneath the system

Conveyor systems more than 4000 mm and up to 6000 mm long: Two belt supports evenly spaced over the length

The T-Slot Nuts provided are used for fastening to the Line 8 profile.



## Double Timing Belt Conveyor 8 40 D

Double Timing Belt Conveyor 8 40 D is available in two widths – 40 mm and 80 mm – and in lengths of up to 6000 mm. The total width of the synchronised belts can be anything up to 2400 mm. This ensures heavy, inherently stable products can be efficiently transported.

## Frame of Double Timing Belt Conveyor 8 40 D



Caution! Before starting work on the belt conveyor, the basic frame needs to be aligned. The two profiles running parallel to one another must be perfectly aligned. Any parallel misalignment between the cut edges should be less than 0.1 mm.



Note! The basic frame's perpendicularity and parallelism should be checked using a measuring square.

## Drive assembly of Double Timing Belt Conveyor 8 40 D

Screw the two flat-head Hexagon Socket Head Cap Screws M8x14 all the way in. These screws help secure a tensioning hook so that the drive assembly can still be adjusted at the end of the assembly process.



The drive assembly first needs to be put together and fastened in place.



To do so, insert the shaft clamping ring into the half of the Drive Unit that will be located opposite the motor. Then, on what will be the half connected to the motor, push the positioning ring from the inside through to the fastening and clip it into place.



Note! At the end of this process, this positioning ring is facing outwards.



Caution! The Double Timing Belt Conveyor must be synchronised via the drive assembly in a subsequent step. Both an inward-facing and an outward-facing positioning ring are thus installed on what will be the motor side, while an inward-facing ring is installed on the opposite side. This means a total of three positioning rings are required.



Next, press the Drive Pulley bearings into the Drive Unit by hand and then, as a ready-made assembly, fit the two halves of the Drive Unit to the sides of the profiles, slotting them into the Line 8 grooves up to the stop and then tightening by hand.

When slotting in the Drive Unit halves, ensure the tensioning hook is positioned correctly in its final position and is not twisted or jammed. The flat-head Hexagon Socket Head Cap Screws M8x14 are used for this purpose.

Leave final fastening until the Timing Belt has been tensioned.



Note! The item lettering is at the bottom and the axial offset from the centre of the profile to the centre of the drive assembly is 1 mm. This is vital to minimise friction.

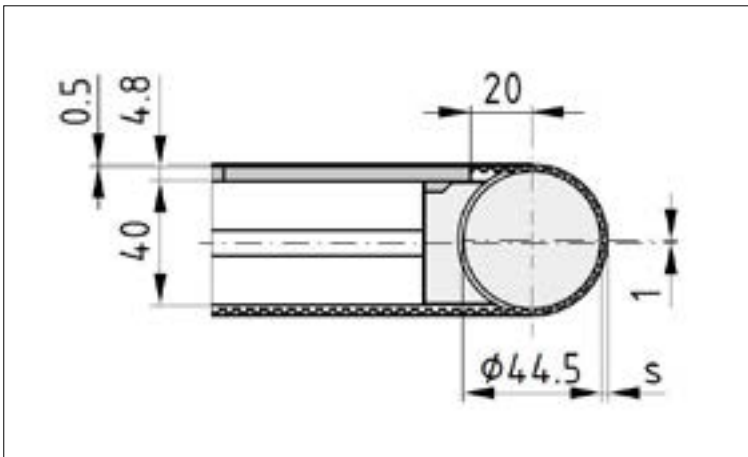

### Return assembly of Double Timing Belt Conveyor 8 40 D

The return assembly is assembled in a similar way to the drive assembly. The profile bores at this end do not need to be machined.



Press the Return Pulley firmly into place in the Return Unit by hand.



Following preliminary assembly, slot the return assembly into the grooves on the side of Profile 8 40x40 or Profile 8 80x40 and then tighten.

$M_T = 10 \text{ Nm}$



Note! The item lettering is at the bottom and the axial offset from the centre of the profile to the centre of the return assembly is 1 mm. This is vital to minimise friction.

### Entry/Output Timing Belt Guide Strip of Double Timing Belt Conveyor 8 40 D

Insert the two double T-Slot Nuts into the profile grooves.



Then screw on the plastic panel loosely, align it and slide it towards the Return Pulley, leaving a gap of approx. 2 mm (distance from edge of plastic to axis of rotation: 20 mm).





Fit the entry/output guide strip at the drive end in exactly the same way. The final position is established once the guide strip has been fitted, after the next assembly step.



Note! Take care not to damage the plastic when subsequently tightening to the required torque.  $M_T = 4 \text{ Nm}$

### Guide strip of Double Timing Belt Conveyor 8 40 D

The length of the Timing Belt Guide Strip is determined in advance with the help of the configurator. However, this length can also be determined by measuring the distance between the entry and output guides. The guide strips have an uncut length of 2 m and can easily be fitted end to end.

When inserting, start at the entry/output of the return end. Simply press the guide strip into the groove and clip it into place. The guide strips are 40 mm wide and are installed side by side in the case of a Profile 8 80x40.



Note! There is a right-hand and a left-hand side! The raised edge of the strip must face outwards.



Recommendation! Cut to size using a saw with a fence, because the cut edge must be square. Multi-Purpose Pliers can be used in theory, but the cut is not sufficiently precise.

### Timing Belt of Double Timing Belt Conveyor 8 40 D

Place the pre-welded Timing Belt over the pulleys and the profile.



Note! If possible, position the profile on its side and wrap the Timing Belt around the profile.

Turn the profile back over. To tension the Timing Belt, the return run on the underside must be able to move freely so as not to obstruct this process. Loosen the drive assembly to enable the Timing Belt to be tensioned.



Caution! Precise and even belt tensioning is vital to ensure the belt conveyor system works properly.



Pre-tension the Timing Belts to achieve an elongation of 0.1 percent. The drive assembly's tensioning screws help with pre-tensioning. These screws must be tightened evenly and alternately.



The Timing Belt tension must be monitored during the tensioning process. There are various ways of doing this, e.g. using a frequency analyser or a steel ruler.



The frequency analyser determines the pre-tensioning value based on the vibration frequency of a defined section of the Timing Belt when it is struck. At a measuring distance of 0.5 m (spacing of the cylindrical pins supplied with the frequency analyser underneath the Timing Belt), a frequency of 50 Hz indicates the necessary pre-tensioning of 0.1 percent.





A steel ruler can also be used to check the Timing Belt tension. The Timing Belt must be able to move freely and must not be clamped in place anywhere. Use the steel ruler to mark a specific distance on the belt. A distance of e.g. 1000 mm is recommended, as this makes the elongation of 0.1 percent easier to check and read off.

Turn the tensioning screws to tension the belt and achieve an elongation of 0.1 percent, that is to say 1/1000th of its total length. In the example with a distance of 1000 mm marked, the necessary pre-tensioning is achieved when the marks have moved a further 1 mm apart, to a total of 1001 mm.

Once the required tension has been achieved, ensure the Timing Belt is running straight by readjusting the drive assembly's tensioning screws. To do so, move the belt by hand in one direction. If the Timing Belt is drifting to the right, against the flanged pulley or guide strip, carefully retighten the right-hand screw of the tensioning mechanism until the belt looks as though it is running straight. If it is drifting to the left, carefully adjust the left-hand tensioning screw.

Once you have adjusted the pre-tensioning and straight running, tighten the drive assembly's fastening screws to the final tightness.

$$M_T = 10 \text{ Nm}$$



Caution! After a test run lasting approx. three hours, check the belt's straight running and tension.

### Synchronisation of Double Timing Belt Conveyor 8 40 D

A Double Timing Belt Conveyor must be synchronised. The drive assemblies have been fitted with their positioning aids facing inward. The third positioning aid is located at the motor side.



First, screw the expanding hub coupling halves that have a shaft to the inside of each drive assembly.  $M_t = 9 \text{ Nm}$



Next, slide the remaining coupling halves onto the synchroniser tube and, starting at one end, align the coupling half with its counterpart and press both halves firmly together. Then push the coupling half on the other end of the tube into its counterpart and press both halves firmly together.



Once the synchroniser tube is sitting between the drive assemblies without any play, screw the couplings firmly to the synchroniser tube.

$M_t = 4 \text{ Nm}$





Caution! Rotating shaft. Spread open a Synchroniser Shaft Cover Profile 8 40 and wrap it around the synchroniser tube. Then use the Safety Seal to seal the safety cover.

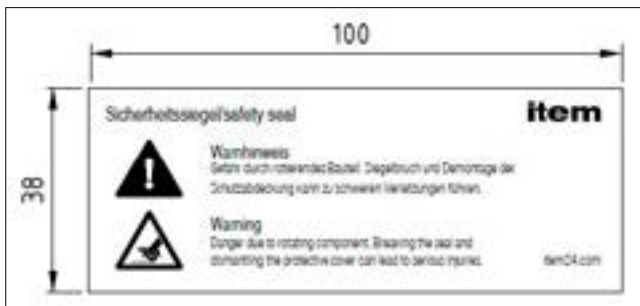

Caution! Once the synchroniser tube cover has been fitted, the seal must be stuck on to seal it. Operation is permitted only if the seal is undamaged.

### Belt Support Set of Double Timing Belt Conveyor 8 40 D

Timing Belts above a certain length need to be supported to avoid sagging and reduce wear. Construction kits for various belt widths are available for this purpose.



Caution! Gaps exceeding 5 mm create danger zones where limbs or tools can be pulled into the system.

The Belt Support Set needs to be fitted for this purpose.



The first step is to fit the deep groove ball bearing to the flat brackets. On these brackets, pre-fit a countersunk screw and a threaded bush for securing (countering) the screw when tightening.



Next, use a mallet to carefully hammer the bearings into both ends of Tube D30. Then use self-tapping screws to assemble the flat brackets with Tube D30, protected in Conduit Profile 8 40x40 SE.

$M_T = 2 \text{ Nm}$

Prepare the brackets for fastening to the side of the conveyor belt's Line 8 profiles and screw into place.

$M_T = 10 \text{ Nm}$



When using belt supports:

For systems 2000 mm long or more, always attach these evenly spaced underneath the conveyor system.

Conveyor systems up to 2000 mm long: No belt support system

Conveyor systems more than 2000 mm and up to 4000 mm long: One belt support halfway along underneath the system

Conveyor systems more than 4000 mm and up to 6000 mm long: Two belt supports evenly spaced over the length

The T-Slot Nuts provided are used for fastening to the Line 8 profile.



## Drive elements

A choice of two motor and gearbox combinations are available as direct drives:

- Motor AC D16 with integrated bevel gearbox (six gear ratios)
- Motor AC D11 with separate Gearbox (six gear ratios)

Using the relevant Motor Fastening Set, both can be used as a plug-and-play solution with all item conveyor belts.

These modular drives share the same benefits:

- The drive can be connected on the right or left of the conveyor belt.
- The position of the Motor can be switched quickly without disassembling the conveyor belt.
- You can choose between four different motor orientations in 90° increments.
- The Fastening Set's expanding hub coupling compensates for slight misalignments of the Drive Pulley.
- Synchronising two or more belts is easy, even after installation.
- A secure cover for the synchroniser shaft protects staff.
- The three-phase AC motor can be fine-tuned using an optional frequency converter.

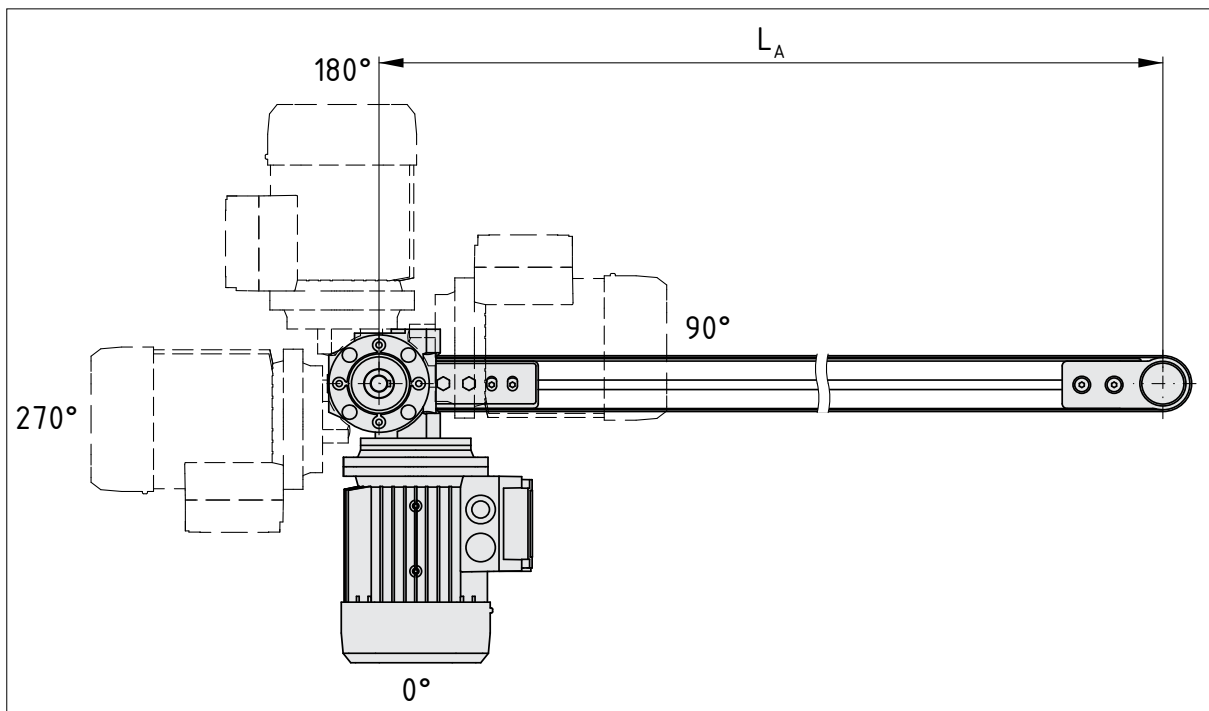

Motor AC D16 is a high-quality electric motor with integrated Spiroplan® gearbox. The bevel gearbox is available in six fixed gear ratios for different belt speeds. Adding an optional frequency converter enables precise adjustment of the conveyor belt's speed. The combination of asynchronous machine and integral bevel gearbox makes assembly easier. What's more, the aluminium housing boasts a very lightweight design and the Motor benefits from quiet operation and a long service life. Motor AC D16 has a high efficiency rating of IE3 to DIN EN 60034-30:2009.

Motor AC D11 is a reliable three-phase AC motor for conveyor belts. You can specify a system's speed very precisely by combining it with a Bevel Gearbox H D14/D11 with the appropriate gear ratio and an optional frequency converter. The asynchro-



nous machine and the Bevel Gearbox are separate units, so Motor AC D11 can be combined with various Gearboxes. Modular design principles make it easier to convert a conveyor line to different speeds and use the same Motor on alternating systems.

Features	Motor AC D16-180W-i6	Motor AC D16-180W-i10	Motor AC D16-180W-i14	Motor AC D16-180W-i19	Motor AC D16-120W-i32	Motor AC D16-120W-i75	Motor AC D11-180W
Nominal power [W]	180	180	180	180	120	120	180
Gear ratio	6.57	10.25	14.33	19.50	32.50	75.00	Without Gearbox
Nominal speed at 50 Hz [rpm]	209.3	134.1	96.0	70.5	42,5	18.4	1370
Nominal torque [Nm]	7	11	14	18	17	25	1.25
Nominal frequency [Hz]	50/60	50/60	50/60	50/60	50/60	50/60	50/60
Nominal voltage [V]	230/400	230/400	230/400	230/400	230/400	230/400	230/400
Nominal current [A]	0.99/0.56	0.99/0.56	0.99/0.56	0.99/0.56	0.71/0.41	0.71/0.41	0.64/1.1
Efficiency class	IE3	IE3	IE3	IE3	IE3	IE3	IE2
Protection class	IP 54	IP 54	IP 54	IP 54	IP 54	IP 54	IP 55
Thermal class [C°]	130	130	130	130	130	130	155
Mass [kg]	6.9	6.9	6.9	6.9	6.1	6.1	3.9

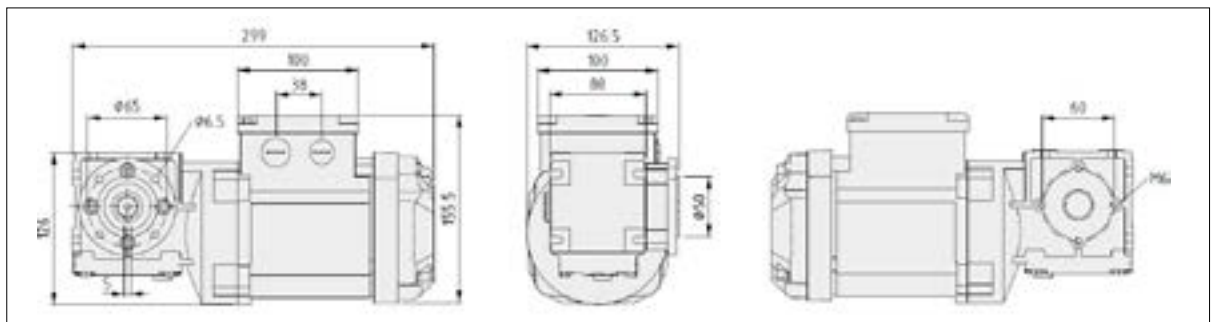

Connection dimensions for Motors AC D16-180W

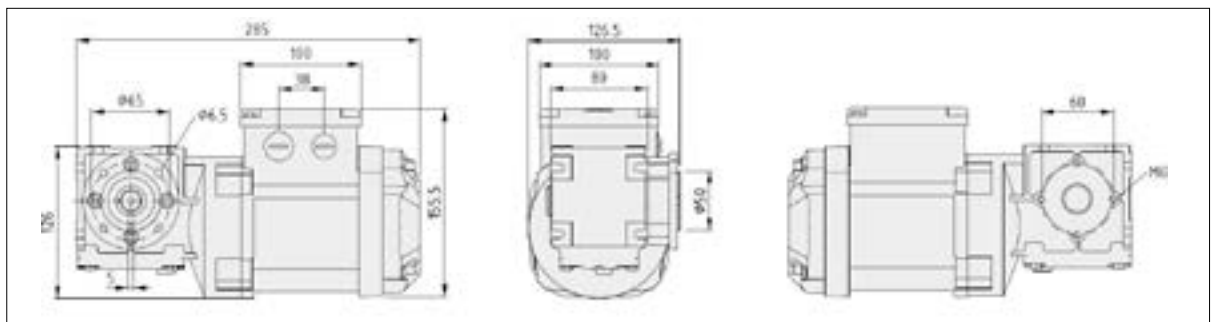

Connection dimensions for Motors AC D16-120W

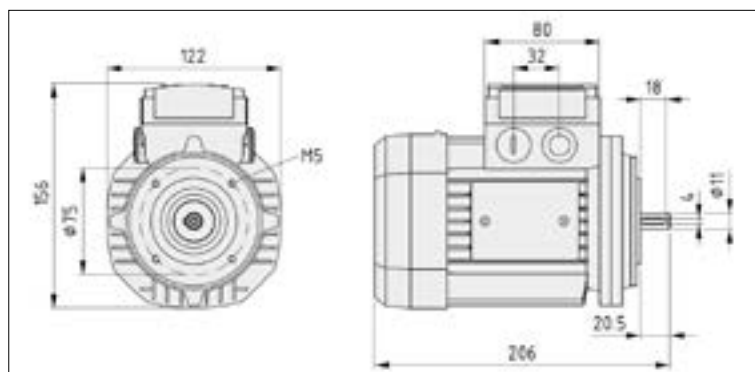

Connection dimensions for Motors AC D11

### Bevel Gearbox D14/D11

Bevel Gearboxes D14/D11 for item Motor AC D11 are available in six gear ratios. As a result, the speed of the conveyor belt can be adjusted. As a plug-and-play solution, the Gearbox is screw-fastened to the Motor without any additional machining. Using Motor Fastening Set 8 40 D14, you can fit the Gearbox and Motor on the right or left of the conveyor belt.

Features	Bevel Gear-box D14/ D11-i7	Bevel Gear-box D14/ D11-i10	Bevel Gear-box D14/ D11-i15	Bevel Gear-box D14/ D11-i20	Bevel Gear-box D14/ D11-i30	Bevel Gear-box D14/ D11-i60
Gear ratio	7	10	15	20	30	60
Efficiency	0.84	0.81	0.76	0.73	0.65	0.51
Output speed at drive speed of 1370 rpm [rpm]	195.7	137.0	91.3	68.5	45.7	22.8
Output torque at motor output of 0.18 kW [Nm]	7	10	14	18	24	38
Nominal output torque [Nm]	16	16	18	18	20	19
Max. output torque [Nm]	48	48	54	54	60	57
Protection class	IP 56	IP 56	IP 56	IP 56	IP 56	IP 56
Mass [kg]	1.1	1.1	1.1	1.1	1.1	1.1

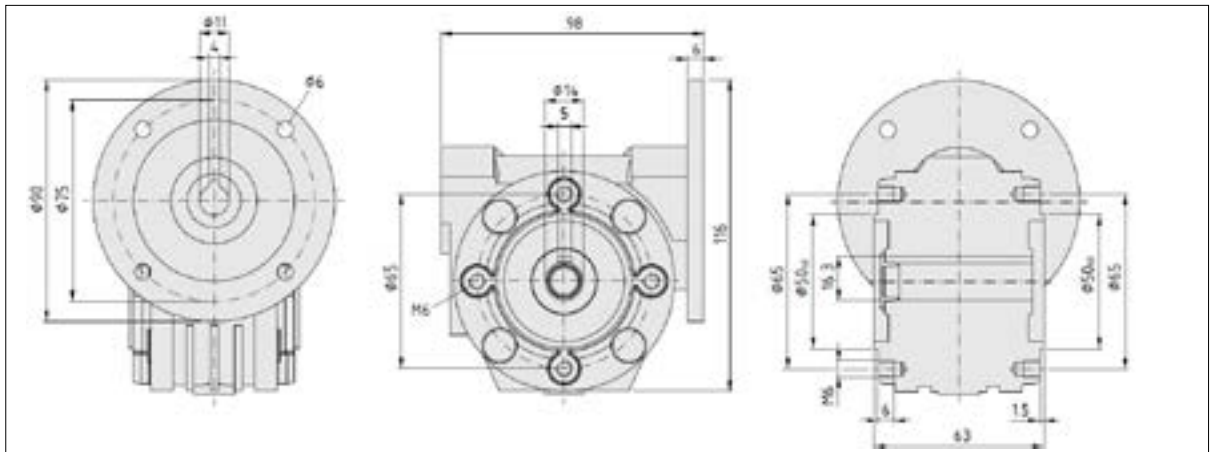

Bevel Gearbox D14/D11

### Motor Fastening Set 8 40 D16

Motor Fastening Set 8 40 D16 is a universal solution for connecting item Motors AC D16 to a conveyor belt. It transfers the torque to the Drive Pulley. The Fastening Set is fitted on the right or left of the conveyor belt, on the drive assembly's housing. The Motor with integrated gearbox is screw-fastened to the torque brace. The drive's orientation can be changed in 90° increments. The drive shaft is pressed into the Motor's hollow shaft without any additional machining. The expanding hub sits securely in the Drive Pulley. The elastomer insert compensates for potential angular errors between the two coupling halves.

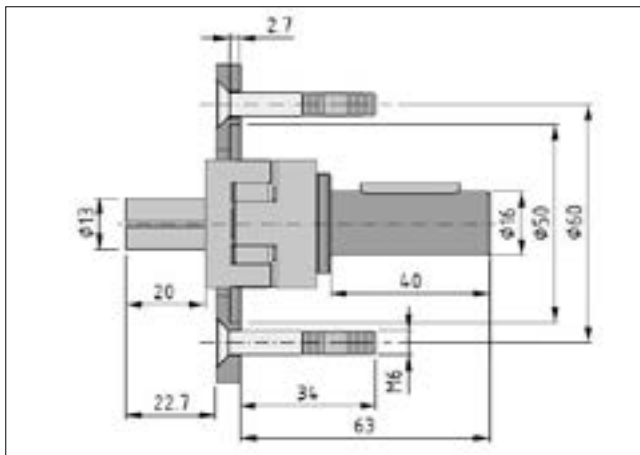

### Motor Fastening Set 8 40 D14

Motor Fastening Set 8 40 D14 combines Bevel Gearbox D14/D11 with the Drive Pulley of a Flat Belt Conveyor or a Timing Belt Conveyor. It is fitted on the right or left of the conveyor belt, on the drive assembly's housing. The Gearbox is screw-fastened to the coupling housing and its orientation can be changed in 90° increments. The drive shaft is pressed into the Motor's hollow shaft without any additional machining. The expanding hub sits securely in the Drive Pulley. The elastomer insert compensates for potential angular errors between the two coupling halves.

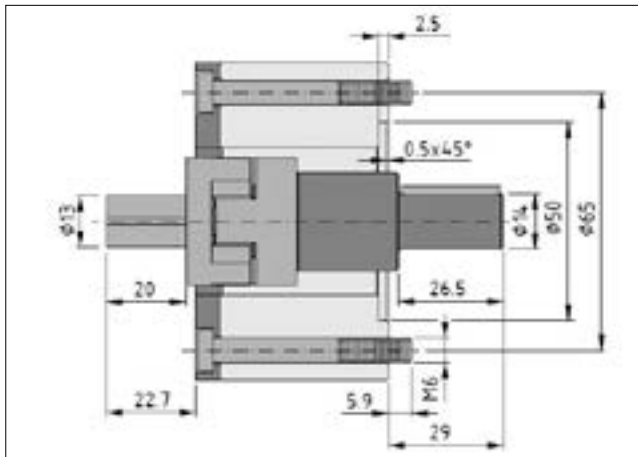

### Synchronising Set 8 40

Synchronising Set 8 40 is used to synchronise two or more conveyor belts. It can also be retrofitted.

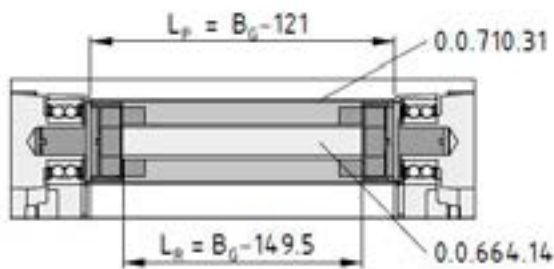

Note! In the case of Double Flat Belt Conveyors and Double Timing Belt Conveyors, the Synchronising Set is included in the scope of supply.

### Synchroniser Shaft Cover Profile 8 40

To protect staff, the synchroniser shaft is covered with Synchroniser Shaft Cover Profile 8 40 K. This can also be retrofitted simply by clipping it on. The positioning ring in Synchronising Set 8 40 (0.0.703.07) ensures it sits correctly. To prevent improper opening of the Synchroniser Shaft Cover Profile, the Safety Seal for Rotating Components (0.0.710.81) must be fitted. This seal is broken when the cover is removed.



Note! In the case of Double Flat Belt Conveyors and Double Timing Belt Conveyors, the Synchroniser Shaft Cover Profile is included in the scope of supply.

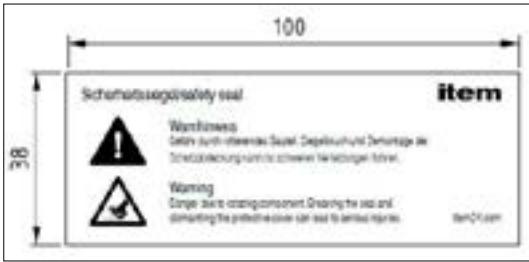
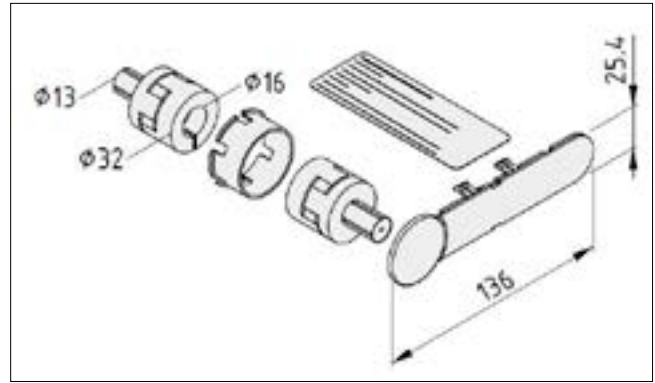

## Fitting Motor AC D11

Motor AC D11 is supplied without a gearbox.

Gearboxes are screw-fastened to the Motor, taking into account the position in which the Motor subsequently needs to be fitted on the flange.

 Caution! When fitting Motors, ensure they are wired properly, including earthing. An electrician must either carry out or supervise and inspect the wiring and the safe integration of the item Conveyor Belt System.



Next, use an 8 A/F spanner to tighten the hexagon screws securely.

$M_T = 5 \text{ Nm}$

Motor Fastening Set of Motor AC D11



Using the torque brace and three flat-head Hexagon Socket Head Cap Screws M6 (4 A/F), screw-fasten the coupling housing to the Gearbox.

$M_T = 10 \text{ Nm}$



Caution! Make use of the centring indentation when placing the coupling housing on the Gearbox.



Use screw fixings to firmly secure the motor shaft with key in one coupling half and insert it into the coupling housing.



Caution! Watch out for the key of the motor's hollow shaft during assembly.



Note! An assembly paste needs to be applied to the motor shaft so that it can subsequently be disassembled.





### Fastening Motor AC D11

Use the Motor Fastening Set to fasten the Motor to the conveyor system's drive assembly. The drive assembly's plastic positioning aid helps you centre the Motor. Use an 8 A/F spanner to tighten the hexagon screws.

$M_T = 14 \text{ Nm}$



Caution! The protective cap supplied seals the Bevel Gearbox's rotating hollow shaft. At the side of the conveyor belt opposite the Motor, the Drive Unit's cap covers the rotating drive shaft.



Note! For its test run, the system is tested and adjusted using a commissioning motor. The recommended test period is approximately three hours. Straight running and the tension of the belt conveyor must be readjusted if necessary.

## Fitting Motor AC D16

Motor AC D16 is a high-quality electric motor with integrated Spiroplan® gearbox. The bevel gearbox is available in six fixed gear ratios for different belt speeds. Adding an optional frequency converter enables precise adjustment of the conveyor belt's speed.



Caution! When fitting Motors, ensure they are wired properly, including earthing. An electrician must either carry out or supervise and inspect the wiring and the safe integration of the item Conveyor Belt System.

### Motor Fastening Set for Motors AC D16



Using the torque brace and three M6 countersunk screws, screw-fasten the coupling housing to the gearbox.

$M_T = 10 \text{ Nm}$



Use screw fixings to firmly secure the Motor shaft with key in one coupling half and insert it into the coupling housing.



Caution! Watch out for the key of the motor's hollow shaft during assembly.



Note! An assembly paste needs to be applied to the motor shaft so that it can subsequently be disassembled.

### Fastening Motors AC D16

Use the Fastening Set to fasten the Motor to the conveyor system's drive assembly. The drive assembly's plastic positioning aid helps you centre the Motor. Use an 8 A/F spanner to tighten the hexagon screws.

$M_T = 14 \text{ Nm}$



Caution! The protective cap supplied seals the bevel gearbox's rotating hollow shaft. At the side of the conveyor belt opposite the Motor, the Drive Unit's cap covers the rotating drive shaft.



Note! For its test run, the system is tested and adjusted using a commissioning motor. The recommended test period is approximately three hours. Straight running and the tension of the belt conveyor must be readjusted if necessary.

## Maintenance and inspection



Before working on the item Conveyor Belt System, disconnect it from the mains.  
Do not reach into the system while it is operating.



Caution! The belt continues running after the system is switched off.  
Structural safety is the operator's own responsibility.  
Caution! A small amount of burrs may be present on bare metal surfaces. Staff must be given appropriate training to avoid accidents and damage to the item Conveyor Belt System.  
Only qualified persons should carry out repairs and modifications.



All products are subject to a natural process of wear and tear that varies according to the relevant conditions of use. The construction's connection points consist of different materials with different material properties. Due to the operating conditions, we recommend they are regularly checked and visually inspected for damage and wear.  
Functionality should be checked after the first 24 hours in operation. After that, it is advisable to carry out maintenance on a quarterly basis. As the manufacturer is unaware of the environmental conditions and conditions of use, users are required to use their own judgement.  
The following aspects should be checked during every service and before/during every use:

### Maintenance checklist

Component/construction	Maintenance/inspection criteria	Comment
Flat Belt	Check for wear and correct pre-tensioning every three months	...
Timing Belt	Check for wear and correct pre-tensioning every three months	...
Tightening torques - fixings	....	
Labelling		
Documentation		
Max. loading values		
.....		

If any damage is identified, the part in question must be replaced immediately.

TS No./SC No./inventory No.:

Signature:

## Spare parts list

Component	Article Number
Expanding hub coupling D16/d13	0.0.702.81
Drive Unit Set 8 40	0.0.702.72
Return Unit Set 8 40	0.0.702.96
Timing Belt Guide Strip 8 40 - 40	0.0.702.98 (Zuschnitt: 0.0.702.99)
Timing Belt Guide Strip 8 40 - 80	0.0.705.82 (Zuschnitt: 0.0.705.93)
Drive Pulley, Flat Belt Conveyor 8 40 - 40	0.0.702.88
Drive Pulley, Flat Belt Conveyor 8 40 - 80	0.0.705.06
Drive Pulley, Flat Belt Conveyor 8 40 - 120	0.0.705.07
Drive Pulley, Flat Belt Conveyor 8 40 - 160	0.0.705.08
Drive Pulley, Flat Belt Conveyor 8 40 - 200	0.0.705.09
Drive Pulley, Flat Belt Conveyor 8 40 - 240	0.0.705.10
Drive Pulley, Flat Belt Conveyor 8 40 - 320	0.0.705.11
Drive Pulley, Flat Belt Conveyor 8 40 - 400	0.0.705.12
Return Pulley, Flat Belt Conveyor 8 40 - 40	0.0.702.92
Return Pulley, Flat Belt Conveyor 8 40 - 80	0.0.705.16
Return Pulley, Flat Belt Conveyor 8 40 - 120	0.0.705.17
Return Pulley, Flat Belt Conveyor 8 40 - 160	0.0.705.18
Return Pulley, Flat Belt Conveyor 8 40 - 200	0.0.705.19
Return Pulley, Flat Belt Conveyor 8 40 - 240	0.0.705.20
Return Pulley, Flat Belt Conveyor 8 40 - 320	0.0.705.21
Return Pulley, Flat Belt Conveyor 8 40 - 400	0.0.705.22
Fine Adjuster Set 8	0.0.715.05
Drive Pulley, Timing Belt Conveyor 8 40 - 40	0.0.709.27
Drive Pulley, Timing Belt Conveyor 8 40 - 80	0.0.709.28
Drive Pulley, Timing Belt Conveyor 8 40 - 40	0.0.709.29
Drive Pulley, Timing Belt Conveyor 8 40 - 80	0.0.709.30



Component	Article Number (cut-off)
Flat Conveyor Belt PVC, non-accumulating - 40	0.0.706.10
Flat Conveyor Belt PVC, non-accumulating - 80	0.0.706.12
Flat Conveyor Belt PVC, non-accumulating - 120	0.0.706.14
Flat Conveyor Belt PVC, non-accumulating - 160	0.0.706.16
Flat Conveyor Belt PVC, non-accumulating - 200	0.0.706.18
Flat Conveyor Belt PVC, non-accumulating - 240	0.0.706.20
Flat Conveyor Belt PVC, non-accumulating - 320	0.0.706.22
Flat Conveyor Belt PVC, non-accumulating - 400	0.0.706.24
Flat Conveyor Belt PVC, accumulating - 40	0.0.706.30
Flat Conveyor Belt PVC, accumulating - 80	0.0.706.32
Flat Conveyor Belt PVC, accumulating - 120	0.0.706.34
Flat Conveyor Belt PVC, accumulating - 160	0.0.706.36
Flat Conveyor Belt PVC, accumulating - 200	0.0.706.38
Flat Conveyor Belt PVC, accumulating - 240	0.0.706.40
Flat Conveyor Belt PVC, accumulating - 320	0.0.706.42
Flat Conveyor Belt PVC, accumulating - 400	0.0.706.44
Flat Conveyor Belt PUR ESD, accumulating - 40	0.0.718.04
Flat Conveyor Belt PUR ESD, accumulating - 80	0.0.718.05
Flat Conveyor Belt PUR ESD, accumulating - 120	0.0.718.06
Flat Conveyor Belt PUR ESD, accumulating - 160	0.0.718.07
Flat Conveyor Belt PUR ESD, accumulating - 200	0.0.718.08
Flat Conveyor Belt PUR ESD, accumulating - 240	0.0.718.09
Flat Conveyor Belt PUR ESD, accumulating - 320	0.0.718.10
Flat Conveyor Belt PUR ESD, accumulating - 400	0.0.718.11
Timing Belt T5 TPU, non-accumulating - 40	0.0.706.56
Timing Belt T5 TPU, non-accumulating - 80	0.0.706.58
Timing Belt T5 PA, accumulating - 40	0.0.706.60
Timing Belt T5 PA, accumulating - 80	0.0.706.63
Belt Support Set 8	0.0.709.55



Component	Article Number
Motor AC D16-180W-i6	0.0.705.44
Motor AC D16-180W-i10	0.0.705.45
Motor AC D16-180W-i14	0.0.705.46
Motor AC D16-180W-i19	0.0.705.47
Motor AC D16-120W-i32	0.0.705.48
Motor AC D16-120W-i75	0.0.705.49
Motor AC D11-180W	0.0.705.69
Bevel Gearbox D14/D11-i7	0.0.710.75
Bevel Gearbox D14/D11-i10	0.0.710.76
Bevel Gearbox D14/D11-i15	0.0.710.77
Bevel Gearbox D14/D11-i20	0.0.710.78
Bevel Gearbox D14/D11-i30	0.0.710.79
Bevel Gearbox D14/D11-i60	0.0.710.80
Motor Fastening Set 8 40 D16	0.0.703.11
Motor Fastening Set 8 40 D14	0.0.705.73
Synchronising Set 8 40	0.0.703.07
Synchroniser Shaft Cover Profile 8 40 K, black	0.0.710.31 (cut-off)
Synchroniser Shaft Cover Profile 8 40 K, black	0.0.707.72

## Disposal



The materials used are environmentally friendly.

The product can be recycled or re-used (after any necessary refurbishment and replacement of parts). The use of appropriate materials and easy dismantling ensure the product can be recycled.



Improper disposal of the Conveyor Belt System can pollute the environment.

Dispose of the Conveyor Belt System in accordance with the national regulations that apply in your country.

The Conveyor Belt System must not be disposed of as ordinary domestic waste at the end of its service life. The separate disposal of used electrical and electronic equipment protects the environment against hazardous substances and materials.

## Warranty

Warranty: 12 months. The warranty covers free delivery of parts or complete units ex-works. However, this is conditional on receipt of a written notice from the customer that includes a description of the fault. The replaced parts must be returned to item Industrietechnik GmbH within six weeks for inspection. Otherwise, the cost of the replacements and their shipping will be charged.

The warranty is null and void if the units are stored even briefly (less than three months) in an environment that lies outside a temperature range of -20°C to +60°C and has a relative humidity (without condensation) exceeding 60 percent.

Start of warranty:

Day of delivery, but no later than three months after delivery!

## Development and documentation

A process of continuous product development ensures that products from item Industrietechnik GmbH always exhibit a high standard of innovation. Consequently, there could be inconsistencies between this guide and the product you have acquired. item Industrietechnik GmbH can also not exclude the possibility of errors. We therefore ask for your understanding that the information, illustrations and descriptions provided here cannot constitute an entitlement to any claims. You can find the latest version of this user guide at [item24.com](http://item24.com).

**item**

item Industrietechnik GmbH  
Friedenstrasse 107-109  
42699 Solingen  
Germany  
Phone +49 212 6580 0  
info@item24.com  
item24.com

03/2023

Made in Germany

item Industrietechnik GmbH

0.0.720.62